

## **Regional Review Workshop on Completed Research Activities**

**Proceedings of Review Workshop on Completed Research Activities of Agricultural Engineering Research Directorate held at Batu Fishery & Aquatic life Research Center, Batu, Ethiopia. 04-09 September, 2017**

**Editors: *Eshetu Ararso, Kamil Ahmed, Ashebir Tsegaye, Jemal Nur and Gelgelo Kibi***

**Designer: Natnael Yisak**



**Oromia Agricultural Research Institute**  
**P.O. Box 81265, Addis Ababa, Ethiopia**  
**E mail [oari.info@gmail.com](mailto:oari.info@gmail.com)**

**FAX 0114, 70, 71, 29 tel. 0114707021**

©2017 Oromia Agricultural Research Institute (IQQO)

ISBN 978-99944-72-02-4



**Correct citation:** Eshetu Ararso, Kamil Ahmed, Ashebir Tsegaye, Jemal Nur and Gelgelo Kibi (eds.), 2017. Proceedings of Review Workshop on Completed Research Activities of Agricultural Engineering Research Directorate held at Batu Fishery & Aquatic life Research Center, Batu, Ethiopia, 2018

*Organized by: Communication & Partnership Process of IQQO*

## **Table of contents**

Design and Development of Engine Operated Coffee Dehulling Machine	1
Adaptation and Evaluation of Engine operated IITA Multi-crop Thresher for Soya bean Threshing	10
Adoption and Evaluation of Engine Driven Groundnut Stripping Machine	19
Adaptation and Evaluation of Top Hammer Miller Machine to Crop Residue Crushing for Livestock Feed Purpose	31
Evaluation of Walking Behind Harvester for Wheat Crop	44
Evaluation of Soybean Thresher for Chickpea Crop	57
Characterization and Redesigning of Mada Batu Small Scale Irrigation Scheme, West Arsi Zone of Oromia Region	68
Redesigning of Ketar Medium Scale Irrigation Scheme, Arsi Zone of Oromia Regional State, Ethiopia	83

# Design and Development of Engine Operated Coffee Dehulling Machine

\*Gelgelo Kibi, Ashebir Hailu

Oromia Agricultural Research Institute, Bako Agricultural Engineering Research Center  
P.O.Box 07, Bako, West Shoa, E-mail:- [gelgelokibi@gmail.com](mailto:gelgelokibi@gmail.com)

## **Abstract**

*About sixty-five percent of the country's coffee production is from Oromia region. In spite of the facts that coffee is highly economical and can boost the farmer's revenue, their earning from the crop is not to the potential. This may be attributed to inadequate processing technology as result of the high level of drudgery involved in the shelling of the coffee bean by manual method. Hence, Bako Agricultural Engineering Research Center (BAERC) decided to develop and evaluate engine operated dehuller that can be affordable by the farmer. The main components of the coffee dehulling include hopper, drum, concave, cleaning and delivery units and frame. The experiment was conducted in a split-plot design having drum speeds in main plots, rear concave clearance in sub-plots with three replications as block. The optimum shelling efficiency of 93.80% was observed when the drum was operated at velocity of 500 rpm and 2mm rear concave clearance; whereas the minimum shelling efficiency of 86.80% was observed when the drum speed was 450 rpm & rear concave clearance was 6mm. At those combination the shelling capacity, mechanical damage and cleaning efficiency of 241.37 and 218.07kg/hr, 5.56 and 3.49%, and 88.13 and 87.59% were obtained, respectively. From the results obtained, regarding the performance of the machine, it can be concluded that the machine can be used by the farmers to dehull coffee at small scale level.*

**Key words:** *Design, development, evaluation, coffee bean, dehulling*

## **INTRODUCTION**

Coffee crop is indigenous plant in Oromia region. It is being planted formerly at small and large scale level in the region with the farmers and planted by landlords in previous emperor. However, it is grown in nature. About sixty-five percent of the country's coffee production is from Oromia region. Approximately, around 617,700 households are involved in coffee production (Oromia Coffee Farmers Cooperative Union, 2002). It is one of very precious items which generate income for farmers and key to country's economy.

Even though, coffee is produced by many households, small scale coffee owner may face constraint in access of very sophisticated coffee processing units. Different manually operated

coffee dehullers from different centers were collected and tested. Due to its limitation of shelling capacity, (51.6 kg/hr for Jima model at feed rate of 0.5 kg/min according to Gutu Birhanu and Ashabir Hailu, 2011), the technology was not used by farmer for mass production rather than seed shelling. Large scale coffee bean shelling available at union but because of its cost the farmer cannot afford it and forced to sell un-dehulled coffee bean to the union with less price.

In spite of the facts that coffee is highly economical and can boost the revenue, their earning from the crop is not to the potential. This may be attributed to inadequate processing technology as result of the high level of drudgery involved in the shelling of the coffee bean by manual method. Hence, BAERC decided to develop and evaluate engine operated coffee dehuller that can be affordable by the farmer.

**Objectives:**

- ❖ To design and develop engine operated coffee dehulling machine
- ❖ To evaluate the performance of the machine

## **MATERIALS AND METHODS**

**Experimental site**

The machine was fabricated at Bako Agricultural Engineering Research Center (BAERC), which is located in West Shoa Zone of Oromia National Regional State, Ethiopia. The Center lies between 9<sup>0</sup> 04'45'' to 9<sup>0</sup> 07'15''N latitudes and 37<sup>0</sup>02' to 37<sup>0</sup>07'E longitudes.

**Description of the machine components**

The main components of the coffee dehulling include hoper, drum, concave, cleaning and delivery units and frame. Materials for machine components are mentioned under the design of its main components as following.



Figure 1. The pictorial representation of the sheller. A– Hopper, B– Drum unit, C– Sieve, D– Delivery unit, E– Frame, F– Fan

## **Fabrication of the Machine Components**

### **Frame**

The frame carries the entire components of the machine. It is a trapezoidal shaped structure constructed from 40 by 40 mm square pipe based on standard minimum ratio of the frame lengths, given as  $L1/L2=0.5$ , (Shirgley 1980, Hannah and Stephens 1980). This was done to provide stability and make it easily transportable.

### **Hopper**

The hopper feeds the coffee bean to be shelled into the shelling unit. The material used for construction is iron sheet metal of 1.5mm thickness. The hopper is semi circularly shaped and extended upwards, depending on the angle of repose of unshelled coffee bean the inlet tilted 30 degree to the horizontal to prevent splashing out of coffee bean during shelling. The beans to be shelled fall into the shelling unit by gravity through the feed table and the feeding rate shall be controlled by the control gate. Angle of repose was taken depend on the recommendation (the minimum is  $23^0$ ) of Olukunle and Akinnuli (2012).

### **Cylinder unit**

The shelling cylinder carried out the function of actually breaking the dry coffee cherry, releasing the kernel from the cherry. It was closed ended rotating cylinder with round bar welded on drum and made up of two circular plate's diameter of 40cm and length of 40cm, which is drilled at the center to allow 30mm diameter shaft to pass through.

### **Concave**

The concave clearance was adjustable and round bar of 6mm diameter was welded at space of 6mm based on the mean thickness coffee kernel determined by Olukunle and Akinnuli, 2012 and fitted to the cylinder length.

### **Cleaning unit**

Fan is centrifugal type and consists of straight blades, welded on shaft inside a casing. The fan casing was spirally shaped for greater blowing efficiency. Additionally, two stage sieve was used in order to separate shelled and unshelled coffee. The sieve hole of oval shape was used by shifting two sieve drilled by 12mm based on the geometric mean diameter of the kernel.

### **Experimental design**

The experiment was conducted in a split-plot design having drum speeds in main plots, rear concave clearance in sub-plots with three replications as block. Three levels of drum speeds ( $V_1 = 450\text{rpm}$ ,  $V_2 = 500\text{rpm}$  and  $V_3 = 550\text{rpm}$ ) and two levels of rear concave clearance ( $C_1 = 2\text{mm}$  and  $C_2 = 6\text{mm}$ ) were used for the study.

### **Statistical analysis**

Data were subjected to analysis of variance using statistical procedure as described by Gomez and Gomez (1984). Analysis was made using GenStat 15th edition statistical software/tool.

### Performance of the prototype

The performance of the machine was evaluated in terms of shelling capacity (kg/h), shelling efficiency (%), cleaning efficiency (%) and percentage of damage (%) using the following equations;

$$\text{Shelling capacity (kg/h)} = \frac{Q_t}{T_m}$$

$$\text{Mechanical damage (\%)} = \frac{Q_d}{Q_{ud} + Q_d} \times 100$$

$$\text{Cleaning efficiency (\%)} = \frac{W_t - W_c}{W_t} \times 100$$

$$\text{Shelling efficiency (\%)} = \frac{Q_t}{Q_t + Q_{us}} \times 100$$

Where:  $Q_t$ –Mass of shelled grain at grain outlet (kg);  $T_m$ – time of shelling operation (h);  $Q_{us}$ – quantity of unshelled grain (kg);  $Q_{ud}$ –quantity of undamaged grain (kg);  $Q_d$ – quantity of damaged grain (kg),  $W_t$ – weight of total mixture of grain and chaff received at the grain outlet (kg);  $W_c$ –Weight of chaff at the main outlet of the thresher (kg).

### RESULTS AND DISCUSSION

Performance of the machine was evaluated interims of shelling capacity (SC), mechanical damage (MD), shelling efficiency (SE) and cleaning efficiency (CE) at moisture content of 11.5%, which is recommended range of coffee bean to be threshed for dry coffee bean. The standard moisture contain for which performance of any dehulling machine to be measured is between 9%-12% (Subedi, 2010).



## Shelling capacity (kg/hr)

Table 1. Effect of drum speed and rear concave clearance on shelling capacity

Source of Variation						
Interaction Effect (VXC)			Main Effect			Grand mean
Velocity (rpm)	Con. Clearance at rear (mm)		Velocity (rpm)	Mean	Clear.(mm)	
	2	6				
450	225.12 <sup>a</sup>	218.07 <sup>a</sup>	450	221.60 <sup>a</sup>	2	239.19 <sup>a</sup>
500	241.37 <sup>b</sup>	237.55 <sup>bd</sup>	500	239.46 <sup>b</sup>	6	236.10 <sup>a</sup>
550	251.07 <sup>c</sup>	252.69 <sup>ce</sup>	550	251.88 <sup>c</sup>		237.64
SE (M)	2.954		2.089		1.706	
LSD (5%)	8.202		5.80		4.736	
CV (%)	1.5					

Means followed by the same letter has no significant difference

The maximum shelling capacity of 252.69 kg/hr was recorded at interaction effect of 550 rpm and 6 mm drum speed and rear concave clearance respectively. Generally, shelling capacity has direct relationship with drum speed but has inverse relationship with rear concave clearance. According to Adekanye and Olaoye (2013) and Adekanye *et al.* (2016), shelling capacity increased slightly with an increased drum speed.

## Mechanical damage (%)

Table 2. Effect of drum speed and rear concave clearance on mechanical damage

Source of Variation						
Interaction Effect (VXC)			Main Effect			Grand mean
Velocity (rpm)	Con. Clearance at rear (mm)		Velocity (rpm)	Mean	Clear. (mm)	
	2	6				
450	4.48 <sup>ab</sup>	3.49 <sup>ac</sup>	450	3.98 <sup>a</sup>	2	5.11 <sup>a</sup>
500	5.56 <sup>b</sup>	4.44 <sup>a</sup>	500	5.00 <sup>b</sup>	6	4.38 <sup>a</sup>
550	5.30 <sup>ab</sup>	5.20 <sup>a</sup>	550	5.25 <sup>bc</sup>		4.47
SE (M)	0.677		0.479		0.391	
LSD (5%)	1.881		1.330		1.086	
CV (%)	17.5					

Mechanical damage has direct relationship with drum speed and inverse relationship with rear concave clearance. Maximum percentage kernel mechanical damage, 5.56%, occurred when the bean were shelled at cylinder speed of 500 rpm and rear concave clearance of 2mm, while

the least kernel mechanical damage, 3.49%, was recorded at drum speed of 450 rpm and at rear concave clearance 6 mm. The percentage of damaged grain increased by increasing the drum speed (El-Nono and Mohamed, 2000) as a result of increased impact force (Abo El-Naga *et al.*, 2013). This implies that using high drum speed for this machine would result in high bean damage which may render hulling operation worthless.

### Shelling efficiency (%)

Table 3. Effect of drum speed and rear concave clearance on shelling efficiency

Source of Variation						
Interaction Effect (VXC)			Main Effect			Grand mean
Velocity (rpm)	Con. Clearance at rear (mm)		Velocity (rpm)	Mean	Clear. (mm)	
	2	6				
450	91.68 <sup>ad</sup>	86.80 <sup>c</sup>	450	89.24 <sup>a</sup>	2	92.81 <sup>a</sup>
500	93.80 <sup>b</sup>	90.71 <sup>d</sup>	500	92.25 <sup>b</sup>	6	88.80 <sup>b</sup>
550	92.96 <sup>ab</sup>	88.88 <sup>e</sup>	550	90.92 <sup>c</sup>		90.80
SE (M)	0.604		0.427		0.349	
LSD (5%)	1.677		1.186		0.968	
CV (%)	0.8					

Analysis of variance revealed that both main effects were highly significant ( $P < 0.01$ ). The optimum shelling efficiency of 93.80% was observed when the drum was operated at velocity of 500 rpm and 2 mm rear concave clearance; whereas the minimum shelling efficiency of 86.80% was observed when the drum speed was 450 rpm & rear concave clearance was 6mm. The shelling efficiency increased with increase in drum speed. Dalha and Dangora (2011) said the threshing efficiency varies with increase in cylinder speed at different feed rates with similar results reported by Raji and Akaaimo (2005), Adekanye and Olaoye (2013) and Adekanye *et al.*, (2016).

## Cleaning efficiency (%)

Table 4. Effect of drum speed and rear concave clearance on cleaning efficiency

Source of Variation							
Interaction Effect (VXC)			Main Effect				
Velocity (rpm)	Con. Clearance at rear (mm)		Velocity (rpm)	Mean	Clear. (mm)	Mean	Grand mean
	2	6					
450	88.17 <sup>ab</sup>	87.59 <sup>b</sup>	450	87.88 <sup>a</sup>	2	88.20 <sup>a</sup>	
500	88.13 <sup>ab</sup>	88.72 <sup>a</sup>	500	88.43 <sup>ab</sup>	6	88.71 <sup>a</sup>	
550	88.29 <sup>ab</sup>	89.83 <sup>c</sup>	550	89.06 <sup>b</sup>			88.45
SE (M)	0.604		0.427		0.349		
LSD (5%)	0.925		0.654		0.534		
CV (%)	1.3						

The maximum cleaning efficiency of 89.83% was obtained when the drum is operated at speed of 550 rpm and rear concave clearance of 6 mm. Raji and Akaaimo (2005) had earlier reported that increase in fan rotation increased cleaning efficiency while increase in air blowing rate increased cleaning efficiency (Bello and Odey, 2011), using centrifugal fan.

## SUMMARY AND RECOMMENDATIONS

### Summary

The maximum shelling capacity of 252.69 kg/hr was recorded at interaction effect of 550 rpm and 6 mm drums speed and rear concave clearance respectively. The optimum shelling efficiency of 93.80% was observed when the drum was operated at velocity of 500 rpm and 2 mm rear concave clearance; whereas the minimum shelling efficiency of 86.80% was observed when the drum speed was 450 rpm & rear concave clearance was 6 mm. At those combination the shelling capacity, mechanical damage and cleaning efficiency of 241.37 and 218.07 kg/hr, 5.56 and 3.49%, and 88.13 and 87.59% were obtained, respectively. From the results obtained, regarding to performance of the machine, it can be concluded that the machine can be used by the farmers.

### Recommendations

From the designed, constructed and evaluated coffee dehulling machine, the following recommendation is hereby given:

1. To improve on the cleaning efficiency fan mechanism should be developed to remove finer particles from the threshed grains.
2. To improve on the grain damage the drum page should be rubber coated to reduce grain damage.

## REFERENCES

- Abo El-Naga, M. H. M. El-Gendy, H.A. and Mosa, E. H. (2015). Evaluation of a Locally Threshing Machine Performance for Threshing Lentil Crop. *Misr J. Agric. Eng.* 22 (2): 376 – 388
- Adekanye, T. A. and Olaoye, J. O. (2013). Performance Evaluation of Motorized and Treadle Cowpea Threshers. *Agric. Eng. Int.: CIGR Journal.* 15(4): 300 - 306.
- Adekanye, T. A., Osakpamwan, A. B. and Idahosa, Osaivbie, I. E. (2016). Evaluation of a Soyabean Threshing Machine for Small Scale Farmers. *Agric. Eng. Int.: CIGR Journal.* 18(2): 426 – 434.
- Adeleke and Ogunjobi, 2016. Conference & 32ND Annual General Meeting of Nigerian Institution of Agricultural Engineers (NIAE), 17th – 20th October, 2011, Ilorin. 32: 139 – 142
- Bello, S. R. and Odey, S. O. (2011). Development and Performance Evaluation of a House Grain Cleaner. In: Proceedings of the 11TH International Conference & 32ND Annual General Meeting of Nigerian Institution of Agricultural Engineers (NIAE), 17th – 20th October, 2011, Ilorin. 32: 576 - 585
- Dalha, I. B. and Dangora, N. D. (2011). Performance Evaluation of RF450 Thresher for Sorghum. In: Proceedings of the 11TH International 9 [www. jinagri.com](http://www.jinagri.com)
- Elnono, M. Ahmed and Allah, H. A. Mohammed (2000). A Study on Power Requirements for Wheat Threshing. *Egypt Journal of Agric. Research* 78(5): 2169 – 2176.
- Gomez, A.K. and A.A. Gomez, 1984. *Statistical Procedures for Agricultural Research.*
- Shirgley. J.E., 1980. *Engineering design*, 4th edition, McGraw-Hill Coy, NY.
- Gutu B. and Ashebir H., 2011. Comparative performance evaluation of different manual operated coffee hullers
- Gomez, A.K. and A.A. Gomez, 1984. *Statistical Procedures for Agricultural Research.*
- Shirgley. J.E., 1980. *Engineering design*, 4th edition, McGraw-Hill Coy, NY.
- Hannah, J. and R.C. Stephens, 1980. *Mechanics of machine* 4th ed. Edward Arnold, London.
- O.J Olukunle and B.O. Akinnuli, 2012. Investigating Some Engineering Properties of Coffee Seeds and Beans. *Journal of Emerging Trends in Engineering and Applied Sciences (JETEAS)* 3(5):743-747(ISSN: 2141-7016)743
- Raghu Nath Subedi, 2010. Comparative analysis of dry and wet processing of Coffee with respect to quality in kavre district, Nepal
- Raji, A.O. and Akaaimo, D.I. (2005). Development and Evaluation of a Threshing Machine for *Prosopis africana* Seed. *Journal of Applied Science, Engineering and Technology*, 5 (1&2): 56-62.
- Shirgley. J.E., 1980. *Engineering design*, 4th edition, McGraw-Hill Coy, NY John Wiley & Sons, New York, p. 357-379.

# **Adaptation and Evaluation of Engine operated IITA Multi-crop Thresher for Soya bean Threshing**

\*Gelgelo Kibi, Ashebir Hailu and Melese Taresa

Oromia Agricultural Research Institute, Bako Agricultural Engineering Research Center,  
P.O.Box 07, West Shoa, Bako, Email: [gelgelokibi@gmail.com](mailto:gelgelokibi@gmail.com)

## ***Abstract***

*Soya bean threshing, in Ethiopia at present, is predominantly manual that employ animal and tractor wheel tramping. These methods of threshing have impact on animal leg and tractor wheel and also cause large damage. In an effort to alleviate some of the problems associated with primary processing of soya bean, motorized soya bean thresher was adapted and evaluated. The machine consisted mainly of a frame, threshing drum, mechanical cleaning unit (sieve), concave, feeding table. The performance of the machine was evaluated in terms of threshing capacity (kg/h), threshing efficiency (%), cleaning efficiency (%) and percent damage (%) at three levels of drum speed of 500, 600 and 700 rpm by adjusting the position of fuel control throttle of the engine and 9% mean grain moisture content were used. The results indicated that the threshing capacity and percentage of mechanical damage increased with an increase in drum speed. From the result obtained cleaning efficiency and percentage of loss has inverse relationship with drum speed. The maximum threshing capacity of 603.63 kg/hr was obtained at 700 rpm drum speed for grain straw ratio of 1:1.27. The percentage of mechanical damage and loss at this operation is 4.38 and 2.75%, respectively. Based on the results obtained, regarding to performance indices, it can be concluded that the machine can be used by the farmers.*

**Key words:** *Adaptation, evaluation, soya bean, threshing*

## **INTRODUCTION**

The soybean is a species of legume, widely grown for its edible bean which has numerous uses. According to agricultural sample survey of CSA (2007), there are 49,642 private peasant holdings that cultivate about 6,352.5 hectares of land and produced 58,489.5 quintals of soybean. The average production therefore, is 9.21 quintals per hectare. At present the use of soybean in Ethiopia is limited to baby foods production.

In this connection, the report of CSA (2007), pointed out that about 16,550 tons of Fafa, Dube, Edget and Meten has been produced in 2006/07 alone which, therefore, implies that about 2,483 tons of soya bean flour has been imported in to the country in 2006/07 alone. This by

itself indicates the presence of huge demand for the product. The area planted with soya bean in Ethiopia has increased rapidly and it is expected to increase further (CSA, 2007).

Nowadays, there is no thresher for individual farmers to thresh local soya beans. Farmers in most areas of western Oromia thresh soya beans using animal tramping and tractor wheel. Due to the strength of soya bean stem animal legs and tractor wheels are damaged while threshing. One of the biggest constraints for increasing the production of soya bean crop in Ethiopia has been the lack of suitable threshing machine of these crops

Regarding to this problem Assella Agricultural Engineering Research Center was evaluating Asella multi crop thresher for soya bean. The maximum threshing capacity of the machine they obtained is 156.84kg/hr. In order to increase soya beans production, the development of a soya beans thresher has therefore become important. Regarding to traditional threshing problems and minimum threshing capacity of Asella multi crop thresher, Bako Agricultural Engineering research center decide to adapt IITA multi-crop thresher and evaluated at farm level.

### **Objectives:**

- ❖ To adapt IITA multi-crop thresher for soya bean threshing
- ❖ To evaluate the adapted thresher for soybean at different speeds

## **MATERIALS AND METHODS**

### **Experimental site**

Modification of the machine was done at Bako Agricultural Engineering Research Center (BAERC), which is located in Western Shoa Zone of Oromia National Regional State, Ethiopia. The Center lies between 90 04'45'' to 90 07'15''N latitudes and 37002' to 37007'E longitudes. The evaluation of the machine was done at Gida Ayana wereda of East Wollega Zone of Oromia.

### **Design considerations**

The following assumptions were considered in the modification of the machine; ability to thresh soya bean capsules without high damage, ease of operation, reduction of the drudgery involved in the traditional methods of threshing, economy to make the machine affordable and within the capacity of the local farmers and material selection for the modification of the machine to reduce the total energy requirements.

### **Description of the Machine components**

The main components of the soya bean thresher include feeding table, threshing unit, cleaning unit and grain outlet (Figure 2.1).

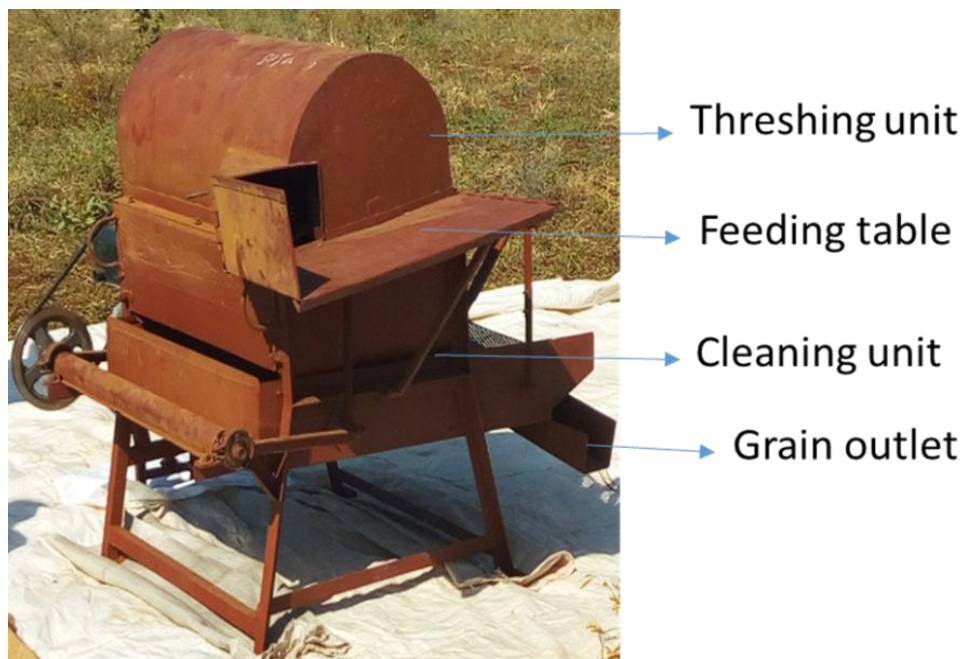

Figure 2.1. The prototype of the thresher

### **Feeding table**

The radial feeding mechanism was modified to axial feeding mechanism that solves the intake speed and problem.

## **Drum**

The threshing drum was fixed with 56 peg-tooth's, each peg was 12 mm in diameter and 60 mm in the length. Additionally, four inclined blades at inlet and straight blades at chaff out let were made. The diameter and length of the threshing drum were 440 mm and 800 mm respectively.

## **Concave**

The concave was made of mild steel rods with spacing of 25 mm depending on the size of soya bean grain. The concave clearance between the threshing drum and concave was fixed at 40 mm.

## **Cleaning unit**

The mechanical cleaning unit (sieve) having 9 mm diameter holes was used. The sieves specifications were selected according to the maximum dimension for the seed (i.e., length).

## **Performance of the prototype**

The performance of the machine was evaluated in terms of threshing capacity (kg/h), threshing efficiency (%), cleaning efficiency (%) and percentage of damage (%) using the following equations;

$$\text{Threshing capacity (kg/h)} = \frac{Q_t}{T_m}$$

$$\text{Mechanical damage (\%)} = \frac{Q_d}{Q_{ud} + Q_d} \times 100$$

$$\text{Cleaning efficiency} = \frac{W_t - W_c}{W_t} \times 100$$

$$\text{Percentage of loss (\%)} = \frac{L_g}{Q_s + L_g} \times 100$$

$$\text{Threshing efficiency (\%)} = \frac{Q_t}{Q_t + Q_{us}} \times 100$$



Where:  $Q_t$ –Mass of threshed grain at grain outlet (kg);  $T_m$ – time of threshing operation (h);  $Q_{us}$ –quantity of unthreshed (kg);  $Q_{ud}$  - quantity of undamaged grain (kg);  $Q_d$  - quantity of damaged grain (kg);  $Q_s$ = quantity of grain sample (kg);  $L_g$ –Mass of loss grain (kg);  $W_t$  = Weight of total mixture of grain and chaff received at the grain outlet (kg)  
 $W_c$  = Weight of chaff at the main outlet of the thresher (kg)

### **Statistical analysis**

Three levels of drum speed 500, 600 and 700rpm (A. Vejasit and V. M. Salokhe, 2004), were used to evaluate the performance of the machine by adjusting the position of fuel control throttle of the engine.

Full feeding rate (the batch that can full the inlet area) that make the farmer easy while using the machine and 9% measured mean grain moisture content that is close to the recommended to be threshed (A. Vejasit and V. M. Salokhe, 2004) were used.

The following data were collected during performance evaluation of the machine

1. Threshed grain were collected at grain outlet, weighed and recorded as  $Q_t$  in kg;
2. Damaged grains, grains with visible damages, at grain outlet were manually picked, weighed and recorded as  $Q_d$  in kg;
3. Chaffs that went out with grains through the grain outlet and chaff outlet were manually collected, weighed and recorded as  $W_t$  in kg;
4. Winnowed chaffs that were separated and discharged through the husk outlet were collected, weighed and recorded as  $W_{hw}$  in kg; and
5. Grains that discharge with chaff were collected, weighed and recorded as  $L_g$  in kg

Data was subjected to analysis of variance using one way ANOVA (no blocking). Analysis was made using Gen Stat 15th edition statistical software.

## **RESULTS AND DISCUSSION**

### **Effect of drum speed on threshing capacity**

Figure 3.1 below shows the effect of drum speed on threshing capacity of the machine. The results indicated that the capacity increased with an increase in drum speed. Increasing drum

speed from 500 to 600 rpm and 600 to 700 rpm increased shelling capacity by 1.33% and 1.49% respectively. The maximum capacity was obtained at 700 rpm drum speed (i.e., 603.63Kg/hr) for grain straw ratio of 1:1.27. The threshing capacity increased by increasing drum speed from 500 to 700 rpm due to the high impact force between drum and biomass that leads to high separation of grains from pods. Vejasit and Salokhe (2004) had earlier reported that increase in drum speed increased threshing. The same trends also obtained by Adekanye *et al.* (2016).

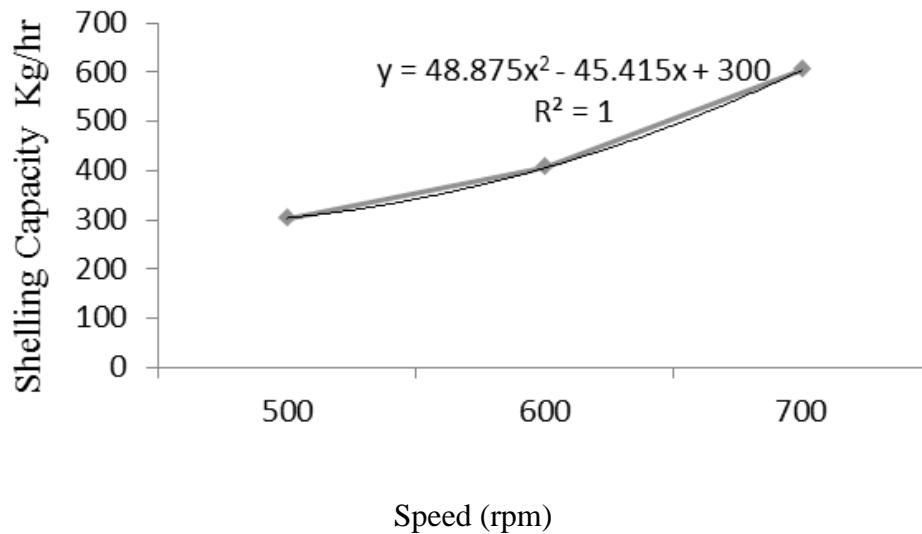

Figure 3.1. Effect of drum speed on threshing capacity

#### **Effect of drum speed on threshing efficiency**

The threshing efficiency of the machine is 100% at all drum speeds. These results were due to low pod cohesion at the range of soybean moisture content tested. This finding is agreed with that of Adekanye *et al.* (2016), Vejasit and Salokhe (2004). They obtained 99.9% threshing efficiency.

#### **Effect of drum speed on cleaning efficiency**

From the result obtained cleaning efficiency has inverse relationship with drum speed. Increasing drum speed from 500 to 600 rpm and from 600 to 700 rpm, decreases cleaning efficiency by 0.90% and 0.99% respectively. This is because of the cleaning unit of the machine is only mechanical, while the drum speed is increase the straw is highly broken due to

the applied impact load and increase the vibration of the sieve causes the broken chaff to pass through the sieve. Increasing drum speed from 500 to 700 rpm decreased cleaning efficiency from 92.83 to 82.24% due to the high impact force of beaters on the chaff that leads to cut and crush the chaff into pieces which fall down with grains. This finding has the same trend as that of Ibrahim *et al.* (2012). The maximum cleaning efficiency was obtained at the 500 rpm drum speed (i.e., 92.83%).

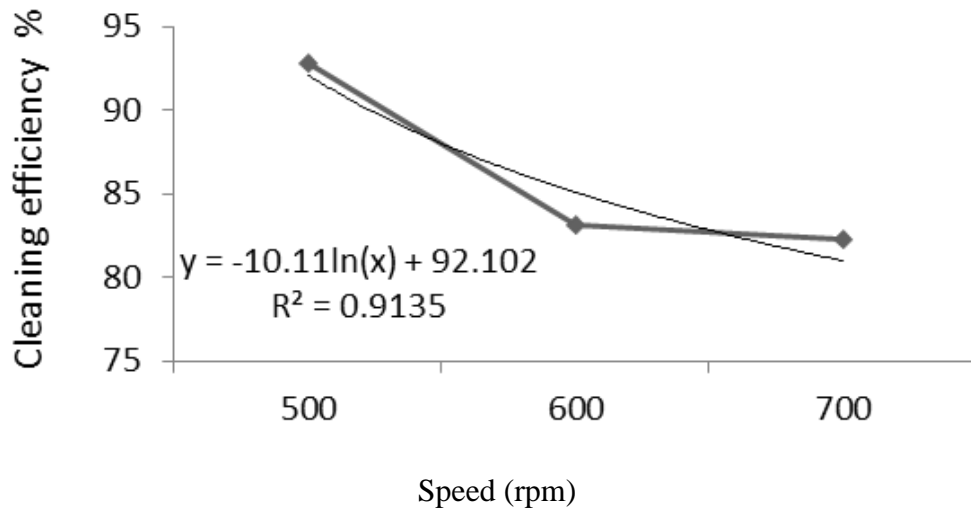

Figure 3.2. Effect of drum speed on cleaning efficiency

### Effect of drum speed on percentage of mechanical damage

The result revealed that, kernel mechanical damage had a direct relationship with the drum speed. This result compares well with the findings reported by Adekanye and Olaoye (2013) for cowpea thresher, Vejasit and Salokhe (2004) for soybean. The maximum percentage of kernel damage of 4.38% was recorded at the 700 rpm drum speed and the minimum 0.45% was recorded at 500 rpm drum speed. This finding was close to that of Kowalczyk (1998). The mechanical damaged he obtained was 5.3% at 18.8–23.5 m/s peripheral drum speed.

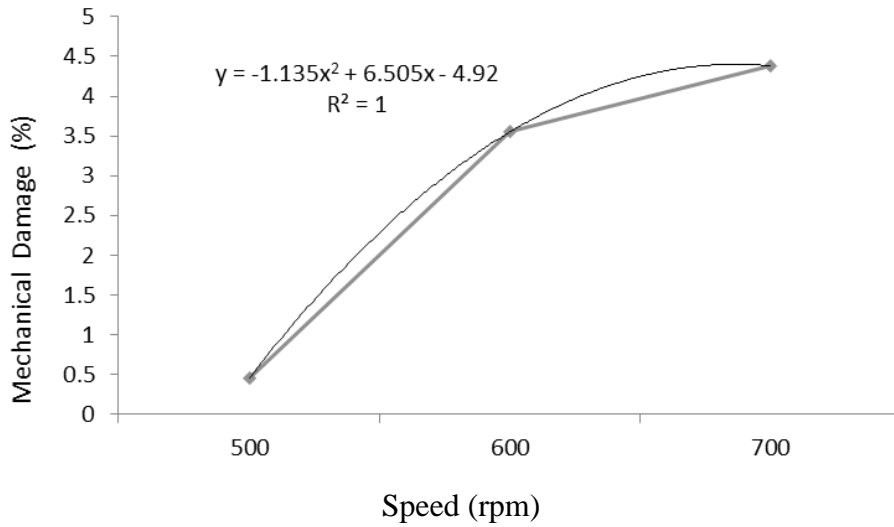

Figure 3.3. Effect of drum speed on mechanical damage

### Effect of drum speed on percentage of grain loss

The maximum percentage of loss of 4.89% was recorded at the 500 rpm drum speed and the minimum 2.51% was recorded at 700 rpm drum speed. This percentage of grain loss not includes grain damage. Increasing impact action due to increasing the drum speed, unlike other seeds soya bean head easily release the kernel, causes threshing the soya bean head at short length of drum. Due to this crop property and length of drum percentage of loss has inversely relationship with drum speed. This decrease is due to the more adequate time to separate seeds from capsules. This result has the same trend as that of (Vejasit and Salokhe, 2004).

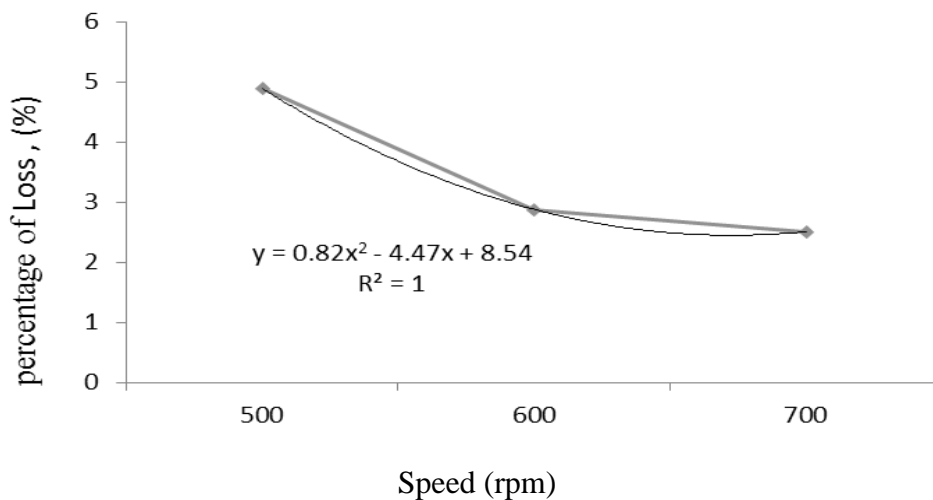

Figure 3.4. Effect of drum speed on percentage of grain loss

## **SUMMARY AND RECOMMENDATIONS**

### **Summary**

Soya bean threshing, in Ethiopia at present, is predominantly manual that employ animal and tractor tramping. These methods of threshing causes injure on animal leg and tractor wheel. Efforts made to alleviate this problems associated with primary processing of soya bean motorized soya bean thresher was adapted and evaluated. Based on the results obtained, regarding to performance indices, it can be concluded that the machine can solve current problem of the farmers.

### **Recommendations**

From the analysis and discussions of the performance result of the test on the Soybean thresher and in order to improve on the performance, the following recommendations should be considered;

1. To improve on the cleaning efficiency fan mechanism should be developed to remove finer particles from the threshed grains.
2. To improve on the grain damage the drum page should be rubber coated to reduce grain damage.

## **REFERENCES**

- Adekanye, T. A., A. B. Osakpamwan, and I. E.Osaivbie. 2016. Evaluation of a soybean threshing machine for small scale farmers. *Agricultural Engineering International: CIGR Journal*, 18 (2):426-434.
- Vejasit and V. Salokhe 2004. "Studies on Machine-Crop Parameters of an Axial Flow Thresher for Threshing Soybean". *Agriculture Engineering International: the GIGR Journal of Scientific Research and Development*. Manuscript PM 04 004. July, 2004
- CSA, 2007. *Agricultural sample survey of area and production of crops of 2006/2007 in Ethiopia Government annual report on area and production of crops*, Addis Ababa, Ethiopia
- Soha G.A. Ibrahim, M.S. El-Shal, M.M. Morad and O.A. Omar, 2012. Development of a machine for shelling green pea. *Zagazig J. Agric. Res.*, Vol. 39 No. (2), p (305 - 318) 2012.

# Adoption and Evaluation of Engine Driven Groundnut Stripping Machine

Jemal Nur

Oromia Agricultural Research Institute, Fedis Agricultural Research Centre, Agricultural  
Engineering Research Process P.O. Box. 904, Harar, Ethiopia  
E-mail: jeminur@gmail.com

---

## *Abstract*

*Groundnut stripping is necessary processes for subsequent harvesting because of pods are attached to most of low acreage groundnut growers. Stripping of pod by hand is very time consuming and drudgery work on farmers. The aim of this study was adoption, evaluation and fabrication of cheap and easily affordable groundnut stripping machine. It was operated by diesel engine capacity of 4 KW motor. The machine has the maximum stripping capacity of 501 kg per hour. The stripping efficiencies of this machine was ranges from 98.2% to 94.7% for wet (immediately after harvest (60% moisture content) at drum speed of 400 rpm and dried for 5 days (17.5 %) moisture content) at 600 rpm operating speed respectively. Both Moisture content of ground vine and operating speed had significant effect on stripping rate and percentage of unstripped pod. Maximum stripping rate (SR) and percentage unstripped pod (PUSP) of a machine was recorded by five days drying after harvest with drum speed of 600 rpm and 400 rpm respectively. While minimum stripping rate and percentage of unstripped pod were recorded at immediate after harvesting with drum speed of 200 and 600 rpm correspondingly. The machine was simple in design and easily manufactured from locally available materials, which makes it cheap and easily affordable, and also easy to operate and maintain.*

**Key words:** Adoption, Groundnut, Stripping rate, stripping efficiency

## INTRODUCTION

Groundnut stripping is necessary processes subsequent to harvesting because of pods are attached to groundnut vines or stem. Local farmers are encountered several difficulties in stripping as it required relatively high expenditure of human energy. Stripping has previously been accomplished either by hammering the pods on the ground to separate pods from it vine or stem. These methods results in serious bruising of human fingers. The most common practice for stripping in irrigated area is to strip within 1 or 2 days after harvesting (Ghatge *et al*, 2014).

Threshing operations also varies both within and among the developing countries. It varies from the age-old procedure of using sticks and racks to the modern power threshers. The smallholder and marginal farmers do manual threshing using sticks and rakes. Variations also exist in stripping pods of the plant. After harvest for example, bunch type plants are stacked in heaps with the pod-end exposed. After the crop has remained in this state for a week or so the pegs become brittle and the pods are plucked from the plants with labor. This operation is comparatively difficult as the attachment of peg to pod is stronger, but drying the plants for a few days facilitates this operation (Nautiyal, 2002).

According to (Nautiyal, 2002) stripping is done by picking pod by pod with an average capacity of 25 kg of pod per man-day. Physical appearance of groundnut from this area is generally good *i.e.* less pods with vine attached and less impurities. For rain fed area, most of groundnut plants are dried in the fields for 4 to 5 days before stripping by pulling a handful of pods from plants.

Ghatge *et al.*, 2014 reported that for poor groundnut quality in term of physical appearance hand or manual stripping could reach up to 62 kg of pod per man-day). Sometimes the stripping of the pods is also performed simultaneously with harvesting when the cropped area is small and laborers are available. In this case, the pods are dried immediately after stripping. The usual practice is to separate pods by beating the pod-end of the plants against a rough stone or a thick iron rod.

Though ground nut production is high, problem of the threshing or stripping have not yet get solution at all areas due to unavailability of modern technology in developing countries like Ethiopia. Unlike others, our farmers not aware of the groundnut threshing technology existence in the world or in home land. Hence, farmers' uses hand stripping by groups of family (*dabo*), which is time taking activity and laborious. Therefore the aim of this study was adopting engine driven groundnut stripper machine at farmer's level to reduce ground nut post-harvest loss.

## MATERIALS AND METHODS

### Description of study area

The experiment was conducted on farmer's field at Jalele kebele of Bable woreda, Eastern Hararge Zone of Oromia Regional State during harvesting time of ground nut (November 2016). Babble is situated at  $09^{\circ} 14' 15'' - 09^{\circ} 25' 05''$  north latitude and  $42^{\circ} 17' 28'' - 42^{\circ} 28' 20''$  east longitude at an altitude of 1670 m a.s.l. It is located at 587 km from Addis Ababa, and 31 km from Harar town. Major crops grown in the study area was sorghum, maize, chat and fruit and vegetable under irrigation. Commonly grown cash crops, in the vicinity of the site, under rain-fed at main season was ground nut and chat.

### Description of the machine components

The main component of the machine consists of frame, engine seat, and stripping blade, feeding table shafts, bearing and pulley. The frame was made from rectangular pipe size 40 mm  $\times$  30 mm with stand height of 1200 mm. Engine seat was manufactured from square pipes of 20 mm  $\times$  20 mm. It was designed to hold engine with better balance and stability during operation.

**Power transmission unit:** the pulley, shaft and A-type V-belt connection was used for power transmission. Shaft having 30 mm diameter was selected in order to transmit required power to different. The experiment was conducted by one cylinder KAMA engine, air cooling, and diesel fuel. The engine output power of 4 kW at full injection operate speed was 1500-1800 rpm

**Stripping unit:** this is a unit which actually strips out the pods from the groundnut.



Table 1: General description of engine driven groundnut stripper

Description	Dimension
Dimensions (l x w x h) (mm)	1300 x 600x 1200
Weight(kg)	90
Cylinder concave (upper and lower cover) diameter x length (mm)	170 x 1100
Beater size or length (mm)	300
Power source (HP)	4KW diesel engine
No. of person required for operation	3 per feed ( used during operation)
<b>Power transmission unit</b>	
Shaft diameter (mm)	30
Diameter of driven pulley (mm)	460
Diameter of driver pulley (mm)	140
V-belt	84 -A-type
Bearings (pair ) P 205 internal Diam. 30 mm	P 205 internal Diam. 30 mm

### Design preparation and prototype production

The detail drawing was prepared before starting manufacturing prototype of a machine. After complete set of drawing and necessary materials were procured, manufacturing of the prototype of stripper was made. Accordingly, the machine covers were prepared from sheet metal of a thickness 1.5 mm on bending and rolling machine. Then Beater was made from flat iron of 4 mm thickness and arranged in circular pattern at an angle of 15<sup>0</sup> degree on flat circular plate at both side and directly hinged on shaft. Frame was made from angle iron and rectangular pipe which was used for complete support of assembled part of the machine.

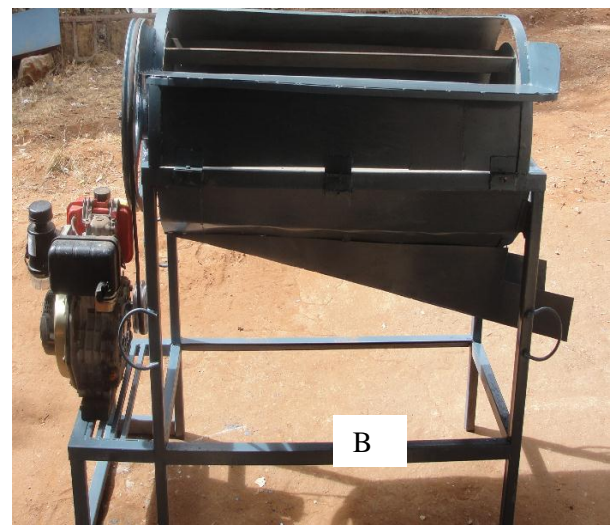
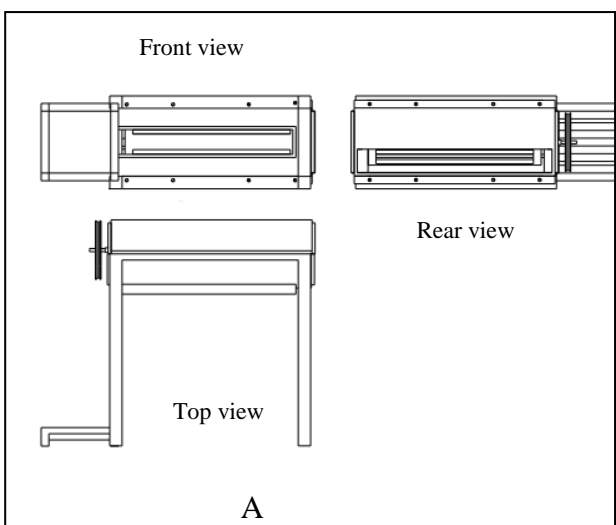

Figure 1: A) Machine drawing and (B) is Prototype of developed groundnut stripper machine

### Performance evaluation of the stripper

After construction, the machine was evaluated on the following parameters:

**Stripping rate (SR):** it was the quantity of the groundnut pods detached from the vein in unit time. It is calculated as according to Ghatge *et al.*, 2014:

$$SR = \frac{WP}{TS} \quad (1)$$

where:- SR - stripping rate ( $\text{kg hr}^{-1}$ ), WP - weight of stripped pod (kg) and TS - stripping time (hr)

**Percentage of unstripped pods:** it was the quantity of the groundnut pods not detached from the vein in unit time and expressed as:

$$PUSP = \frac{WUSP}{TWP} \times 100 \quad (2)$$

where:- PUSP - percentage of unstripped pods, WUSP - weight of unstripped pods (kg) and TWP - total weight of pods (kg)

**Stripping efficiency (SE) :** SE (%) was calculated according to (Afify *et al.*, 2007) following FAO 1994 outline equation

$$SE = \frac{WSP - LOSS}{TWP} \times 100 \quad (3)$$

where: SE - stripping efficiency (%), WSP - weight of stripped pod (kg) and TWS - total weight of pod (kg)

### Experimental procedure

The performance test of the machine was conducted with three levels of drum speed (200, 400 and 600 rpm) and two levels of moisture content (immediately after harvest at average moisture level as 60% in mass bases and drying for 5 days after harvest with normal sun shine moisture level as 17.5%). Using the two experimental factors above i.e S and M, a total of 6 experiments with three replications were conducted in order to determine the range of drum

speed and moisture content that gives the best performance of the machine. Moisture measurement was done by weighing wet sample at harvest and dry sample following procedures outlined by FAO, 1994 on weight base by taking leave and branch stem of groundnut. Moisture content was determined using oven dry at 105<sup>0</sup> C for 24 hour. Three samples were collected and arranged for each factors and replicated 3 times at each machine operating speed and moisture levels. Performance evaluation was made following FAO (1994) procedure and criteria for evaluation of threshing machine parameters which includes stripping efficiency (SE), stripping rate (SR), stripping time (ST) and percentage of unstripped pods (PUSP).

### **Experimental design**

A randomized completely blocks design experimental set up was used. A layout of 3 levels of drum speed (200 rpm, 400 rpm and 600 rpm) by 2 levels of moisture content (dry (17,5%) and wet (60%)) in a randomized complete block design form was used in three replications as follows. W x S<sub>I</sub> is Wet treatment with speed of 200 rpm, W x S<sub>II</sub> is Wet treatment with speed of 400 rpm W x S<sub>III</sub> is Wet treatment with speed of 600 rpm, D x S<sub>I</sub> is Dry treatment with speed of 200 rpm, D x S<sub>II</sub> is Dry treatment with speed of 400 rpm, D x S<sub>III</sub> is Dry treatment with speed of 600 rpm Remark: Drying was done with normal sun shine for five days and moisture was measure by oven at 105<sup>0</sup> C for 24 hour.

### **Data analysis**

All data were subjected to analysis of variance appropriate for factorial randomized complete block design (RCBD). The data were analyzed using statistix-8 software. The mean separation was made using fisher protected list significant difference (LSD) method.

## **RESULTS AND DISCUSSION**

The test was conducted with three persons at a time feeding for groundnut pod stripping machine operation. The constructed groundnut stripper was used to carry out the performance evaluation. The results of the mean performance parameter for the groundnut stripper at two moisture contents for different engine speeds are presented as follow;

### **Stripping rate**

ANOVA result indicated that stripping rate (SR) of machine was highly significantly ( $p < 0.01$ ) affected by both working speed and moisture levels (immediately after harvest moisture level and drying time of 5 day after harvest with normal sun shine). The highest mean stripping rate of a machine  $5.01 \text{ kuntal hr}^{-1}$  ( $\text{K hr}^{-1}$ ) recorded by treatment drying 5 days after harvest stripping with 600 rpm ( $\text{D} \times \text{S}_{\text{III}}$ ). While minimum mean  $\text{SR}_{\text{rate}}$  of machine was  $2.73 \text{ K hr}^{-1}$  by  $\text{W} \times \text{S}_{\text{I}}$  treatment (Table 2). The result revealed that average stripping rate of the machine, at immediately after harvest moisture level with drum speed 200 rpm was 45.5 % lower than drying 5 days after harvest with drum speed  $\text{S}_{\text{III}}$  (600 rpm) with same average feeding rate of  $345 \text{ kg hr}^{-1}$ . This showed that treatment dried for a 5 days stripped with drum speed of 200, 400 and 600 rpm found as 25.54%, 33% and 21.77% higher than moist treatment (stripped immediate after harvest) with the same operating speed respectively. This is resulted from fresh stripping take more time than dry stripping, but percentage of unstripped pod was opposite. On the other hand from the result SR was more affected by moisture than operating speed.

Gol and Nada (1991) reported that important factors affecting the efficiency of mechanical pod stripping elements are operating speed and crop conditions. Percentage of stripping pods increased by increasing of peripheral drum speed which ranged from (473 rpm)  $0.1 \text{ m s}^{-1}$  to (675 rpm)  $3 \text{ m s}^{-1}$ . According to Ajayi (1991) moisture content of the crop influences the capacity of a locust bean thresher. Threshing effectiveness was also found to be affected by the cylinder speed.

Ghatge *et al.* (2014) explained that most of groundnut plants are dried in the fields for 4 to 5 days before stripping by pulling a handful of pods from plants, this method of stripping results in a relatively high capacity ( $62 \text{ kg of pod man}^{-1}\text{day}^{-1}$ ), from this result deduced value of stripping rate per person per hour for 8 hour working time  $62 \text{ kg}$  and for one hour is  $7.75 \text{ kg hr}^{-1}$ . Therefore average stripping rate per hour of dried groundnut pod stripped by machine was 10.74 times or 90.69% higher than when stripped by person or traditional hand stripping method.

## Stripping efficiency

The stripping efficiency of a machine was affected by different operating parameters such as moisture content and stripping drum speed. ANOVA result shows that machine stripping efficiency was highly significantly ( $p < 0.01$ ) affected by stripping drum speed, but moisture level had not significant ( $p < 0.05$ ) effect on machine stripping efficiency. The highest mean stripping efficiency found as 98.2% by fresh stripping of 17.5% moisture level on weight basis) with  $S_{II}$ (400 rpm) drum operating speed and the lowest 94.7% was recorded by 5 days drying before stripping with 600 rpm drum speed (Table 2). The result showed that increasing operating speed reduces stripping efficiency and increase pod loss. On the other hand dry threshing increases the excessive plants leaves or chaff drop, but stripping immediately at harvest 60% ML shows good stripped pod quality but slightly reduce output or stripping rate of machine.

Afify *et al.* (2007) reported that increasing feed rate from 600 to 900 kg hr<sup>-1</sup> at constant drum speed of 6.28 m s<sup>-1</sup> and seed moisture content of 13.63%, decreased the stripping efficiency by 0.97%. According to Simonyan and Oni (2001) there is an increase trend in threshing efficiency and extractor efficiency with decrease in moisture content. Threshing effectiveness was found to be affected by the cylinder speed.

Table 2: Effect of moisture level and operating speed on groundnut stripping machine

Treatment	WSP (kg)	WUSP (kg)	SR <sub>rate</sub> (K hr <sup>-1</sup> )	PUSP (%)	Loss(kg)	SE (%)
D x S <sub>II</sub>	5.89 <sup>a</sup>	0.110 <sup>a</sup>	4.13 <sup>b</sup>	1.82 <sup>a</sup>	NA	97.3 <sup>a</sup>
D x S <sub>I</sub>	5.74 <sup>a</sup>	0.095 <sup>ab</sup>	3.49 <sup>bc</sup>	1.61 <sup>ab</sup>	0.03 <sup>b</sup>	97.5 <sup>a</sup>
D x S <sub>III</sub>	5.13 <sup>b</sup>	0.084 <sup>b</sup>	5.01 <sup>a</sup>	1.56 <sup>ab</sup>	0.10 <sup>a</sup>	94.7 <sup>b</sup>
W x S <sub>I</sub>	5.46 <sup>ab</sup>	0.085 <sup>b</sup>	2.73 <sup>c</sup>	1.53 <sup>ab</sup>	NA	98.1 <sup>a</sup>
W x S <sub>II</sub>	5.39 <sup>ab</sup>	0.074 <sup>b</sup>	2.76 <sup>c</sup>	1.35 <sup>b</sup>	0.02 <sup>b</sup>	98.2 <sup>a</sup>
W x S <sub>III</sub>	5.50 <sup>ab</sup>	0.048 <sup>c</sup>	3.73 <sup>b</sup>	0.84 <sup>c</sup>	0.10 <sup>a</sup>	95.6 <sup>b</sup>
LSD	0.494*	0.022 <sup>NS</sup>	0.841 <sup>NS</sup>	0.402 <sup>NS</sup>	0.042 <sup>NS</sup>	1.62 <sup>NS</sup>
CV	4.9	14.8	12.7	15.2	54.3	0.9

## Percentage of unstripped pod (PUSP) and pod loss

Threshing capacity of a machine could be affected by different physical characteristics of crop. ANOVA result indicated that percentage of unstripped pods (PUSP) was highly significantly ( $p < 0.01$ ) affected by moisture level whereas, But statistically, operating speed had significant

effect ( $p < 0.05$ ) on percentage of unstripped pods. The highest mean PUSP recorded as 1.82%, for 5 days drying after harvest (17.5%) moisture level with ( $S_{II}$ ) of 400rpm drum speed and the lowest PUSP 0.84% was found for immediately at harvest moisture content 60% with ( $S_{III}$ ) 600 rpm drum operating speed.

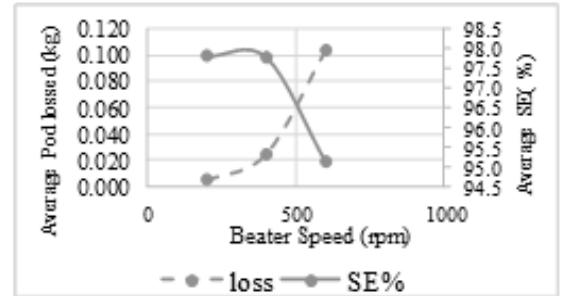

Analysis of variance showed that pod loss was highly (Fig 2) ( $p < 0.01$ ) affected by operating speed, but statistically moisture content had no significant ( $p < 0.05$ ) impact on pod loss. More over statistical output showed pod loss was not affected by moisture content of ground nut vine, whereas operated speed had significant effect on pod loss i.e. as beater speed increase pod scattered out increases.

From the plotted graph between pods loss versus drum speed plotted at initial selected machine operating speed 200 rpm there is no pod loss, but at second drum speed (400 rpm) pod scattering was slightly observed as shown in Table 2. While at 600 rpm and above drum speed stripped pod loss increase as show on the figure 2.

Figure 2 indicates as drum speed increased pod loss or pod scattering increasing, which means, explicitly SE was also influenced by those operation. The SE initially low at 200 rpm and increasing gradually; reached at maximum at 400 rpm then decreasing gradually figure 3.

The result obtained by Afify *et al.* (2007) confirmed with this study. The result showed that decrease in the percentage of stripping efficiency by increasing feed rate is attributed to the excessive plants in the threshing chamber. Consequently, the seeds leave the device without complete stripping from the capsules. Additionally their finding reveals increasing drum speed from 4.19 to 7.32  $m\ s^{-1}$  at constant feed rate of 600  $kg\ h^{-1}$  and seed moisture content of 13.63% increased the stripping efficiency by 1.31%.

### Stripped and unstripped pod weight

ANOVA output show that weight stripped or threshed pod weight (WSP) of groundnut was

statistical significantly ( $P < 0.05$ ) affected by interaction effect of moisture level and operating

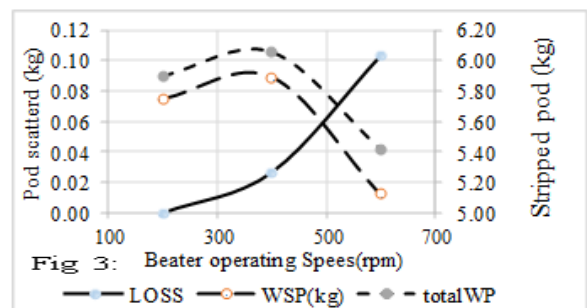

Fig 3: Beater operating Speeds (rpm)

Legend: LOSS (solid line with blue circles), WSP(kg) (dashed line with orange circles), total WP (dashed line with grey circles)

speed. The highest mean stripping was produced by D x S<sub>II</sub> as 5.89 kg and the lowest 5.13 kg by D x S<sub>III</sub>. This is due as beater speed increase stripped pod scattering was higher. Unstripped pod weight of groundnut was highly significantly ( $P < 0.01$ ) influenced by both of moisture level and operating speed. The highest mean weight of unstripped pod recorded 0.110 kg by drying time of 5 day after harvest with S<sub>II</sub> beater speed and the lowest 0.048 kg immediately after harvest with operating speed (W x S<sub>III</sub>). The result revealed that unstripped pod slightly increased on drying for 5 days by normal sun dried than fresh instantly tripped groundnut.

Paulsen *et al.* (1980) indicated that the moisture content of grain is one of the major physical factors for the design and operation of the threshing machine that affect the mechanical damage to grains and threshing efficiency of machine.

### **Economic analysis of the machine**

Handful pulling of pods from plants, stripping method results in a relatively 62 kg of pod/man-day this shows stripping rate per person per hour for one hour is  $7.75 \text{ kg hr}^{-1}$  Ghatge, *et al.* (2014). Economic benefit of stripper was estimated following Rajasekar, *et al.* (2017). Economic analysis of stripper was calculated as follow:

Total stripping per man per hour = 7.75 kg

Working hour = 8 hour per day

Total stripping per 3 mans per day =  $3 \times 7.75 \times 8 = 186 \text{ kg}$

Cost of laborer per day = 100 birr

Total Cost of Manual piking per day = 300 birr

Fuel consumption per hour = 0.8 liter

Total fuel required  $0.8 \times 8 \text{ hr} = 6.4 \text{ liter}$

Cost of fuel with oil = 20 per liter

Total fuel cost per day =  $6.4 \times 20 = 128 \text{ Birr}$

Average Machine stripping per hour = 364.2 kg

Total machine stripping kg per day =  $364.2 \times 8 = 2913.6 \text{ kg}$

Total cost = Labour cost + Fuel cost =  $3 \times 100 + 128 = 428 \text{ Birr day}^{-1}$

Stripping cost per day = (Total machine stripping kg per day/ Total cost) =  $(2913.6 \div 428) = 6.81 \text{ Birr per day}$

Total stripping per 3 mans per day =  $3 \times 62 = 186$  kg

From the calculation: manual stripping cost per 3 mans per day = 300 Birr to strip 186 kg and

machine stripping cost per 3 mans per day = 428 Birr to strip 2913.6 kg

## CONCLUSION AND RECOMMENDATIONS

A groundnut stripping machine was adopted and tested in mandate area of Bable district East Hararge zone. This machine was tested under two factors namely, two moisture level (immediate after harvest and stripping after drying for 5 days), and three machine operating speed, ( 200 rpm, 400 rpm and 600 rpm ); from the conducted test the finding cloud concluded as follows:

The highest mean stripping rate of a machine was  $5.01 \text{ kungal hr}^{-1}$  ( $\text{K hr}^{-1}$ ) was recorded by 5 day drying(17.5%) and drum speed of 600rpm (D x S<sub>III</sub>) treatment. While minimum mean stripping rare ( $\text{SR}_{\text{rate}}$ ) of the machine found  $2.73 \text{ K hr}^{-1}$  was obtained at immediate after harvest (60%) and drum speed of 200(W x S<sub>I</sub>) treatment with same average feeding rate of  $345 \text{ kg hr}^{-1}$ . The highest mean stripping efficiency was recorded by treatment immediate harvest stripping with (S<sub>II</sub>) 400 rpm drum operating speed 98.2% and the lowest 94.7% obtained from stripping after dried for 5 day with (S<sub>III</sub>) 600 rpm drum operating speed.

The highest mean machine stripping time was recorded by fresh harvested stripping with 200 rpm drum speed at immediate after harvest (60% ML) found 0.020 hr. While mean minimum stripping time was at drying for 5 day after harvested with drum speed (D x S<sub>III</sub>) was 0.0106 hr. Generally it can be conclude that drying before stripping resulted in best output (total stripped pod) with (400 rpm) beater speed when compared with threshing immediate at harvest. More over drying after harvest with drum speed (S<sub>III</sub>) stripping produce the highest stripping rate though it resulted in high pod scattering, percentage of unstripped pod and chaff and impurity.



## REFERENCES

- Afify M. K., El-Sharabasy M. M. A., Ali M. M. A. 2007. Development of A Local Threshing Machine Suits for Threshing Black Seed (*Nigella Sativa*), *Sisr J. Ag. Eng.*, 24(4): 699-724
- Ajayi, A. O. (1991): Design of a stripper for locust bean. *Agricultural Mechanization in Asia, Africa and Latin America (AMA)* 22(3): 21-24
- FAO (1994): Testing and evaluation of Agricultural Machinery and Equipment. Principles and practices. Food and Agricultural Organization (FAO) Agric. Services Bulletin No. 110
- Ghatge, J.S., P.S. Bandgar and S.A. Mehetre, 2014. Development and performance evaluation of pedal operated groundnut pod stripping machine. *International Journal of Agricultural Engineering*, Volume 7 Issue-1, Pp. 217–220
- Gol, A. K. and S. K. Nada (1991): Performance of power operated groundnut stripper. *AMA*, 22(3): 25-28
- Nautiyal, P.C., 2002 *Groundnut: Post-Harvest Operations*. National Research Centre for Groundnut (ICAR) ([www.icar.org.in](http://www.icar.org.in))
- Paulsen M. R; R. S. Newberry and W. R. Nave (1980): Soya bean quality with rotary and conventional threshing. *Transaction of ASAE* 23(2):303- 308.
- Simonyan K. J. and K. C. Oni (2001): Performance evaluation of a motorized locust bean decorticator. *Journal of Agricultural Technology* 9(1): 55 - 65.

## **Adaptation and Evaluation of Top Hammer Miller Machine to Crop Residue Crushing for Livestock Feed Purpose**

Abayineh Awgichew\*, Getachew Hailu, Abulassen Keberedin, Abe Tullo  
Oromia Agricultural Research Institute, Asella Agricultural Engineering Research Center  
P.O. Box 06, Asella Ethiopia

\*corresponding author e-mail: - [abaw2001@gmail.com](mailto:abaw2001@gmail.com)

### ***Abstract***

*Crop residues are considered among the most important materials in Ethiopia especially maize stalk, bean stalk, sorghum stalk, and wheat and barley straw. There are many types and models of imported top hammer miller in Ethiopia to assist in milling the grain. Those machines which are imported have many problems such as size of mill and rusting of hammers which not advisable to human food. Therefore the machines adapted and evaluated for livestock feed process purpose in terms of crop residues like maize stalk, bean stalk and wheat straw with predetermined feed rate and hammers' shaft speed (RPM). The research was conducted at Asella Agricultural Engineering Research Center (AAERC), Maki and Bokoji district to evaluate the machine performance in crushing maize stalk, bean stalk, and wheat straw for animal feed. In this paper, two top feed hammer mills were used. They are collected from market and Bako Agricultural Engineering Research Center (BAERC). The performance of the machine is evaluated in terms of crushing capacity, crushing efficiency and crushing loss. The output of the market top hammer miller was satisfactory. The market top hammer miller produced a highest crushing efficiency and capacity about 99.33 % and 152.54 kg/hr while the BAERC's was produced 94% and 78.68 kg/hr, respectively. The crushing losses of the market top hammer miller were 2.67, 0.67 and 5 % on maize stalk, bean stalk and wheat straw respectively.*

**Key words:** *crushing capacity, crushing loss, crushing efficiency, RPM*

## INTRODUCTION

Ethiopia has the largest livestock population in Africa (wiki, 2017, CSA, 2015/16). The livestock subsector comprised 11 percent of national GDP and 24 percent of agricultural GDP and is a source of revenue for 60–70 percent of the population. Between 2005 and 2008, livestock population (in terms of cattle, sheep, and goats) in Ethiopia grew at 22 percent. Oromia region produced the largest share, 38 percent of livestock within Ethiopia, while Amhara and Southern Nations, Nationalities, and Peoples (SNNP) regions produced 26 and 16 percent of livestock shares, respectively according CSA, 2013

Livestock play a central role in the natural resource-based livelihood of the vast majority of the population living in developing countries. However, most of these regions face the problem of acute shortage of feed resources. The pastures are degraded and poorly managed and the area under green forage crops is shrinking due to increase in human population and urbanization (FAO, 2012).

In other hand, Agricultural farming is characteristics of huge scrap and waste material. On completion of harvesting activities, the biomass is invariable left in the fields to decay naturally or disposed of by burning away. However, a small part of the biomass is used as domestic fuel and cattle feed. Normally, farmers pay a great attention to collection of the widely scattered and strewn stem fragments in the field owing to high cost of labor as also that of transporting the stalk to the place where it store or consumption. In general, there is no alternative processing technology for farmers, that the agricultural crop residue can be put to productive use and products of significance.

On the national scene prospect, the quantity of biomass so generated is certainly very large. This underlines the undisputed need for effective end use this form of agricultural waste. Huge quantity of biomass in the form of stalk, if systematically collected and processed, can be gainfully deployed for produce animal feed.

### **Problems statement**

Livestock feed preparation is a great problem nowadays. Earlier time there is grazing area. But now the quest to increase the agricultural production in all surfaces, have intensified crop production by increasing cultivated areas causes reducing the grazing areas. Livestock farmers especially in the sector of goats, sheep and cattle are constantly faced with problem of feed shortage during the dry season. During this period, grazing livestock lose weight and in extreme cases some deaths do occur. As a result, bulky of feeds available for ruminants in these regions are the crop residues. The crop residues have low nutritional value and are bulky and fibrous. In addition, these feed resources are also not well managed, especially where these are available in plenty. Availability of crop residues varies with season and region. In some regions there is deficiency of crop residues only in certain seasons, in others a perennial deficiency may prevail, while in some other regions and in particular seasons they are available in abundance but are largely wasted. Thus, straws worth millions of dollars are burnt in the fields in these places after the grain harvest. Apart from the wastage of a potential feed, the burning of straws causes environmental pollution and degradation of soil fertility. Improvement in the management of crop residues enables efficient utilization of this potentially useful feed resource.

So, in order to help and address the problem of small- scale farmers and develop it into a modern production sector strengthening the intermediate technology were essential.

### **Objective**

To adapt and evaluate the top hammer miller machine to crush crop residue for livestock feed purpose.

## **MATERIALS AND METHODOLOGY**

### **Experimental site description**

The experiment was conducted at Asella Agricultural Engineering Research Center (AAERC), Oromia Agricultural Research Institute (IQQO) located at 6° 59' to 8° 49' N latitudes and 38° 41' to 40° 44' E longitudes, having an elevation of 2430 meters above sea level (m.a.s.l), at

Meki, which is located at latitude and longitude of 8°9'N 38°49'E with an elevation of 1636 meters above sea level and Bekoji which is located at latitude and longitude of 7°35'N 39°10'E with an elevation of 2810 m.

### **Description of the Machine**

Two top feed hammer mills, collected from market and Bako agricultural engineering research center (BAERC) were used and the major components of the top feed hammer millers machine are the frame, pulleys, hopper, sieve, and hammer and hammer house. Figure 1 show both machines used in the experiment.



Figure 1. Machines used during experiment (A=Machine from Market, B=machine from BAERC)

### **Sieve size determination**

Determination of the sieve hole size was done depends on the recommended particle size for different animals. According to the Egyptian standard specification for prepared animal feeds and feedstuffs, compressed feeds are sized into four categories a) sizes < 2mm in diameter ranked: powder or mash, which was used for all types of poultry and birds. b) sizes 2-6mm in diameter, which was used for rabbits, goats and fishes. c) Sizes 5-10mm in diameter for small

animals (<6months). d) Sizes 10-22mm in diameter for large animals (>6months) (Basiouny and Yamani, 2016).

### **Modified parts**

The modification was done on parts of market hammer. These parts are engine sit, sieve whole size, bearing frame. Originally the hammer miller is designed to mill grain so the sieve is too small to mill crop residue for animal feed purpose. Therefore sieve size is selected from 2 to 6, 10 and 12 mm diameter accordingly. The Bearing frame changed from flat iron to angle iron due to repeatedly broken during high load.

**Crushing material** The tested materials were maize stalk, bean straw, and wheat and barley straw after threshing.

### **Working Principle**

A 12 hp ACME diesel engine was used as source of power to operate the machine during the entire work of the experimental investigation. The machine was adopted to employ a combination of hammering and sieving principles to crush and mill the crop residue. Crop residue was prepared and subjected to the hammer through the hopper with predetermined rate. Then the rotating hammer bit the crop residue in the hammer house until, it abled to pass through the sieve to the outlet. The hammer mill is conventionally a hammer-like projection mounted on a rotating shaft. The hammers are hung in such a way that they can swing either ways depending on centrifugal force or impact on the materials. The hammers revolve at high speed and crush the materials fed into its chamber by beating. Hammer size, number and arrangement are very important. Hammers are usually installed on high speed shafts. The distant between the screen and hammer should be 12 to 14 mm for size reduction of cereal grains and about 5mm for fibrous material (HOQUE *et al.*, 2007). But according this experiment the distance is fixed to 2.5 cm.

### **Measuring devices and instruments**

Cole-Parmer 8204 tachometer, with measuring range of 62 to 19999 rpm and having a resolution of 1rpm was used to measure the speeds of shafts. SALTER Model 235 6S – digital

spring balance, made in England capacity of 50kg with 200g difference, was used to measure weights of samples before and after crushing the experiments.

### **Preparation of samples**

Samples for experimental investigations were prepared from materials obtained after threshing of wheat and bean, and after harvesting of maize. Three kilogram of samples with three replications were taken, crushed and weighed to determine the mass of crushed materials before and after commencing on the experiment. The samples prepared were fed at the rate of 3kg at predetermined hammer shaft speed (1200, 1800 and 2200RPM).

### **Performance evaluation**

During each test run materials inserted in the hopper and leaving through the outlet (mass before and after crushing) were weighted using digital balance Performance evaluation of the top hammer mill was made on the basis of crushing efficiency, crushing capacity, crushing loss and fuel consumption. As per Hesham *et al.*, 2015 crushing efficiency and capacity as well as crushing losses were calculated using Eq. (1, 2 and 3).

#### **1. Crushing efficiency (CE)**

$$CE = \frac{\text{Mass of materials after crushing}(kg)}{\text{mass of materials before crushing}(kg)} \times 100\% \quad (1)$$

#### **2. Crushing capacity (CC)**

$$CC = \frac{\text{total mass of materials crushing}(kg)}{\text{total time taken}(hr)} \quad (2)$$

#### **3. Crushing losses (CL)**

$$CL = \frac{M_b - M_a}{M_b} \times 100\% \quad (3)$$

Where  $M_b$ =mass before crushing (kg)

$M_a$ = mass after crushing (kg)

### **Estimation of fuel consumption**

**Fuel consumption:** to measure the fuel consumption, first top hammer mill kept on leveled surface. The fuel tank was filled up to top of the tank before the test started. After the completion of the crushing operation the engine was stopped and then the tank refilled to the

original level. The quantity of fuel filled in the tank was measured using measuring cylinder and taken as actual fuel consumption.

### **Statistical analysis**

Data were subjected to analysis of variance following a procedure appropriate to the design of the experiment as recommended by Gomez and Gomez (1984). Analysis was made using statistix 8.0 statistical software. The treatment means that were different at 5% and 1% levels of significance were separated using LSDT. Level of significance (P) for these relations was obtained by F- test based on analysis of variance.

## **RESULT AND DISCUSION**

### **Primary testing**

The crusher defined as the machine or the tool which designed and manufactured to reduce the large materials into smaller chunks (Hesham et al., 2015). It could be considered as primary, secondary or fine crushers depending on the size reducing ratio. Crushers classified depending on the theory of the crushing acting as, Jaw crusher, conical crusher and impact crusher. The impact crusher type is widely used in agricultural applications, these crushers use the impact rather than the pressure to chuck and break the materials.

Both of the market and Bako Agricultural Engineering Research Center (BAERC) Top hammer miller were impact type crushers and fixed in the crushing of crop residues. The crushers have been feeding by different materials which were available in the test site. The feeding materials were, maize stalks, bean and wheat straws. The primary performance evaluation includes, crusher feed rate, productivity (output materials), and crushing and materials loss.

Each sample was weighted (mass before crushed) and passed through the feeding chute (hopper) into the crushing chamber, coming into contact with the pivoted hammers. The crushed materials were collected through the perforated screen below the crushed chamber. The time taken to crush each sample was recorded. The collected materials were weighted as



mass after crushed. Each test replicated three times. The specific crushing resistance increases with the increase of the stalks fed through the chute.

Table1. Each top Hammer miller test results on different trial

Parameters	BAERC Top hammer miller			Market top hammer miller		
	Maize stalk	Bean straw	Wheat straw	Maize stalk	Bean straw	Wheat straw
Crushing efficiency (%)	98±1.9	94±2	97.33±4	97.33±1.5	99.33±1.6	95±2.1
Crushing capacity (kg/hr)	92.78 ± 3	78.68 ± 2.5	109.75±2.6	119.21±1.3	152.54±2.2	109.1±1.7
Ave. Crushing loss (%)	2 ± 0.1	6 ± 0.5	2.67±0.37	2.67±0.6	0.67±.02	5±0.3
Average Fuel consumed for all stalk (lit/qnt)	0.35			0.3		

From Table 1, it was observed that the market top crusher/ hammer machine give more crushing capacity, crushing efficiency than the BAERC top crusher/hammer machine and produced less crushing loss at different feed rate. Fuel consumption of top hammer mill machine was a little varies from crop to crop residue but not significant. As shown from Table 1 the average fuel consumption of Market and BAERC top hammer miller machines on all stalks for crushing of one quintal crop residue were 0.3 and 0.35 liter respectively.

### **Effect of speed (rpm) on crushing capacity**

Nikolov (2004) stated a general scheme of crushing process as the impact breakage takes place in a very few time and results into a dynamic crack propagation that leads to much faster failure of particles at high speed. Increase in hammer shaft rpm, in general, lead to increasing crushing capacities on both BAERC and Market machines as shown in Figure 2. The mean values of crushing capacity were increased from 60 to 169 kg/hr for BAERC and 74 to 189 kg/hr for market top hammer mill machines respectively as rpm increase from 1200 to 2200 for all stalks on maize stalk. This was due to the fact that at higher hammers speed the crop residue forced to the crushed because of high inertia force acting on them.

### Combined effect hammer speed and feed rate on tested parameters

Analysis of variance made in Table 2 indicates that the effect of feed rate was highly significant ( $p < 0.01$ ) on crushing capacity and crushing loss, and significant ( $p < 0.05$ ) on crushing efficiency. Whereas, hammer speed (RPM) was highly significant ( $p < 0.01$ ) on all crushing efficiency, crushing capacity and crushing loss. Feed rate and straw/stalk (FR x ST), hammer speed and Feed rate (RPM x FR) and straw/stalk and hammer (ST x RPM) combinations had highly significant ( $p < 0.01$ ) effect on both Crushing capacity and crushing loss except that ST x RPM combination had significant effect at  $P < 0.05$  on crushing efficiency.

Table 2. Analysis of Variance Table for the result of the experiments

source of variation	D.F	F-value		
		Crushing Efficiency	Crushing Capacity	Crushing Loss
Replication	2			
FR	2	1.7*	2.03**	1.23*
ST	2	10.45	1.64*	9.61*
RPM	2	5.38**	13.88**	5.76**
ST*RPM	4	3.06*	1.23**	3.27**
FR*ST*RPM	12	3.27**	4.27**	2.79**
Error	26			

\*, \*\*; significant at 5% and 1% probability level, respectively; D.F degree of freedom

Crushing capacity and crushing loss were dominantly affected by feed rate and hammer speed (RPM) and followed by the type of stalk or straw. The interaction between Feed rate, type of straw/stalk and feed rate was highly significant on crushing efficiency, crushing loss and crushing capacity.

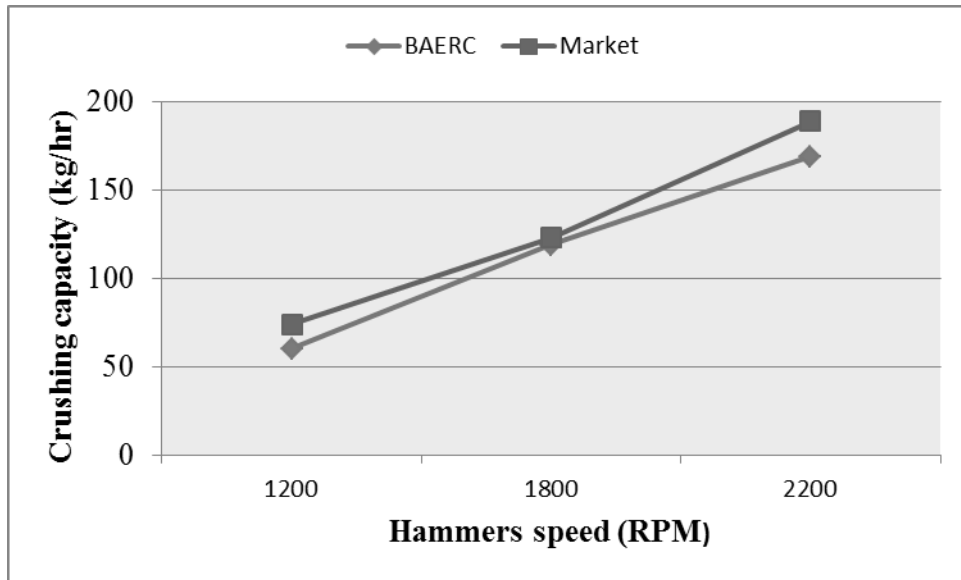

Figure 2. Effect of hammer's shaft speed on crushing capacity

**Effect of Hammer Speed on crushing efficiency and crushing loss**

As can be seen from Figure 3 increase in hammer shaft speed from 1200 to 1800 RPM increased crushing efficiency from 78 to 97%; further increase in hammer shaft speed, to 2200 RPM, resulted in slightly decreasing crushing efficiency to 96% on maize stalk. The trend of graph is similar for each crop residues. The result obtained was similar with Deepak (2008) stated that in an impact crusher the breakage take place in less time at high speed with slightly low efficiency.

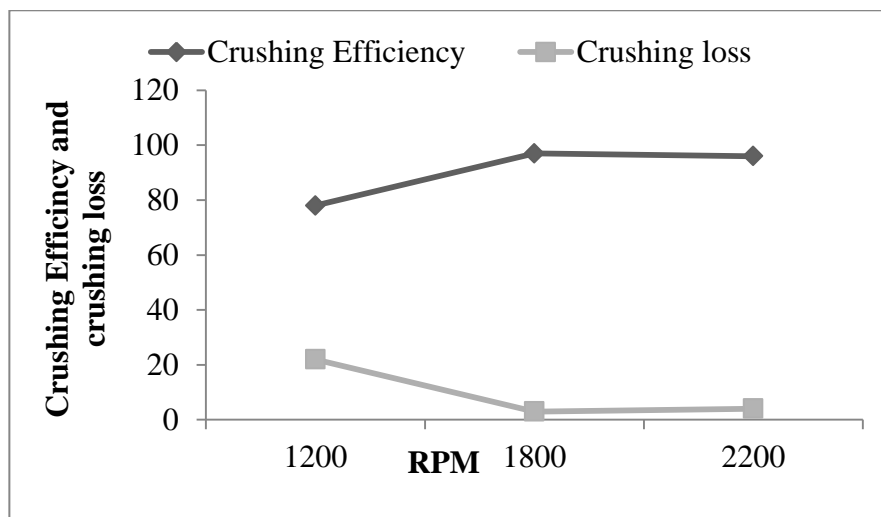

Figure3. Effect of rpm on crushing efficiency and crushing loss (maize)

The crushing loss decreased from 2.2 to 3% when hammer shaft speed increase from 1200 to 1800 RPM. Nonetheless, the Crushing loss increased to 4% as hammer shaft increased from 1800 to 2200 RPM as shown in Figure 3.

### Cost analysis of the Machine

The cost of the machine includes raw material cost and production (machine and labor) cost only. Materials wastage and overhead costs are estimated from raw material and production cost.

Table 3. The summarized cost of the machine without engine

No.	Variable	Cost (ETB)	
		market	BAERC
1	Raw material	7560.63	9086.8
2	Materials Wastage = 2.5% of 1	189.02	227.17
3	Production (machine +labor)	1354.33	2006.45
4	Overhead = 5% of 3	67.71	100.32
5	Profit = 10 % of (1+2+3+4)	917.17	1142.1
6	Sell tax =15% of (1+2+3+4+5)	1513.33	1884.43
7	Selling price = (1+2+3+4+5+6)	11602.19	14447.27

## SUMMARY AND CONCLUSIONS

Performance evaluations of the machines were done to determine crushing capacity, crushing efficiencies and associated losses at different speeds and constant feed rate. Three levels of hammer speed (1200, 1800 and 2200 rpm) were investigated to identify the optimum combination of the variables in question. The top hammer millers/crushers were subjected to test using available material such as Maize stalk, bean stalks and wheat straw with different hammer shaft speed.

Based on the performance evaluation made and results obtained, the following conclusions can be drawn

- The outputs of the top hammer millers were satisfactory. The market top hammer miller produced a highest crushing efficiency and capacity about 99.33 % and 152.54 kg/hr while it was 94% and 78.68 kg/hr when using the BAERC one respectively

- The crushing losses the market top hammer miller were 2.67, 0.67 and 5 % on maize stalk, bean stalk and wheat straw respectively.
- Where BAERC top hammer were 2, 6 2.67 % on maize stalk, bean stalk, wheat and barley straw respectively
- It is recommended to use the Market one top hammer mill for it is better performance and simplicity, save the cost, easy of transportation and it is less in weight, simplicity in operation.

### **Recommendations**

Based on the findings obtained, the following recommendations are made:

- ❖ Since the top hammers millers were originally designed for milling grain, the uniformity of feed materials (crop residue) into the crushing unit was not consistent; hence an automatic feeding or feeding table system and regulator must be developed and used instead of hopper,
- ❖ Lack of a variable electric or hydraulic motor made the use of diesel engine a must and control of speeds at different level was through reduction of engine speed, which was felt inappropriate; hence, further test, using power sources with digital variable speeds be made,
- ❖ The machine was tested and found satisfactory. However ,a flywheel was attached to the hammer mill shaft to stop the lowering of the diesel engine speed noticed whenever much raw material was added to the chamber and
- ❖ Finally, It is decided that future commercialization shall been incorporating with feeding table system regulator and a flywheel at the hammer mill shaft.

## REFERENCES

- Basiouny, M. A. and A. E. El-Yamani, 2016. Performance Evaluation of Two Different Hammer Mills for Grinding Corn Cobs. *J. Soil Sci. and Agric. Eng., Mansoura Univ.*, Vol. 7 (1):77- 87, 2016
- Central Statistical Agency (CSA). 2013. Ethiopia Agricultural Sample Survey Addis Ababa. Volume III. Report On Livestock and Livestock Characteristics (Private Peasant Holdings). Federal Democratic Republic of Ethiopia
- Central Statistical Agency (CSA) of the Federal Democratic Republic of Ethiopia 2015/16. Ethiopia Agricultural Sample Survey Addis Ababa. Volume II. Report On Livestock and Livestock Characteristics (Private Peasant Holdings).
- Deepak, G. (2008). Design and analysis of a horizontal shaft impact crusher, thesis degree, National Institute of Technology (NIT), India.
- FAO. 2012. Crop residue based densified total mixed ration – A user-friendly approach to utilise food crop by-products for ruminant production, by T.K. Walli, M.R. Garg & Harinder P.S. Makkar. *FAO Animal Production and Health Paper No. 172*. Rome, Italy.
- Gomez, A.K. and A. A. Gomez. 1984. *Statistical Procedures for Agricultural Research*. John Wiley & Sons. New York, USA.
- Hesham, A., Yasser, M., Hanafi A. , Radwan and Tarek H., 2015. Redesign and Manufacture an Impact Crusher Hammer Mill Using Advanced Iron Casting. *Global journal of advanced research*. Vol-2, Issue-7 PP. 1196-1209
- HOQUE M., SOKHANSANJ S., NAIMI L, BI X AND LIM J (2007). Review and Analysis of Performance and Productivity of Size Reduction Equipment for Fibrous Materials. *ASABE paper no: 076164 St Joseph, Mich.*, pp2-6.
- Nikolov, S. (2004). Modeling and simulation of particle breakage in impact crusher. *International journal of mineral processing* 74s: 219 – 225.
- Wiki love Africa, 2017. Agriculture in Ethiopia (Available at [https://en.wikipedia.org/wiki/Agriculture\\_in\\_Ethiopia](https://en.wikipedia.org/wiki/Agriculture_in_Ethiopia))

## Evaluation of Walking Behind Harvester for Wheat Crop

Ashebir Tsegaye<sup>\*</sup>, Abulasan Qabaradin, Asnake Tilaye, Dinka Fufa  
Oromia Agricultural Research Institute, Asella Agricultural Engineering Research Center  
P.O. Box 06 Assela Ethiopia E-mail: [tsegayegashebir@gmail.com](mailto:tsegayegashebir@gmail.com)

### Abstract

*The walking behind harvester (TNS Model 4S-120 imported) was evaluated for its performance by harvesting of wheat during 2015/16 harvesting season. The field experiments were carried out at Kulumsa Agricultural Research Center research field. Parameters and measurements considered during this study were crop parameters, operating parameters of the harvesting machine, harvesting losses and cost of harvesting. The average effective field capacity and field efficiency of the harvester was found to be 0.182 ha/h and 81% respectively whereas the effective field capacity in manual harvesting was 0.008 ha/h. Fuel consumption of the reaper was 0.92 lit/h, 5.08 lit/ha. Average value of harvest losses in mechanical harvesting was 1.42 percent only whereas average value of harvesting losses in manual harvesting was 1.73% which is more than that of mechanical harvesting. The cost of harvesting for harvester and for manual harvesting were 479Birr/ha and 1600Birr/ha respectively. The percent saving in the cost of harvesting is reduced by 30% harvesting of wheat with harvester over manual harvesting. Hence, the machine harvesting would be feasible and economical compared to manual harvesting method in terms of time, money and labor requirement.*

**Keywords:** *walking behind harvester, field capacity, field efficiency, harvesting lose.*

### INTRODUCTION

Ethiopia is an agrarian economy with a mainly rain fed agricultural system, where wheat (*Triticumvulgare*) and barley are among the main cereal crops which contribute about 68.3% of the national food grain production (CSA, 2008). Ethiopia is the second largest wheat producing country in Africa followed to South Africa. Wheat is mainly grown in the central and south eastern highlands during the main (Meher) rainy season (June to September) and harvested in October-November. Arsi, Bale, and parts of Shoa are considered the wheat growing belt.

Harvesting is one of the most important operations of farming. Most of the parts of the country have been harvesting manually. This is a labour intensive seasonal operation consuming about 18-20% of the labour required for growing cereal crops (Singh *et al.*, 2008). The traditional method of harvesting with sickle is both labour as well as time consuming, where both are scarce during the peak harvesting season. Labour scarcity during peak period of harvesting

leads to delay in harvesting and field grain losses. Also high labour cost during peak period adds extra cost in total cost of harvesting.

Mechanized harvesting is an alternative solution to tackle this problem. As a step towards mechanization of the harvesting operation for cereal crops, the alternatives available were considered such as self-propelled combine harvesters and tractor mounted combine harvesters. The uses of combine harvesters have their limitations. The farmers want to recover both grains as well as the straw from wheat crops, because the straw is main source feeds of the cattle. Moreover, Ethiopian farmers' fragmented and small farm size holdings, over 69 percent of smallholder farmers in the cereal growing own farmlands less than or equal to one hectare (CSA, 2013). However, high level harvesting combine harvester is not affordable for them.

Most of the cereal crops are harvested by sickle which is quite tedious and labour-intensive job. During the peak season of harvesting, farmers face the difficulty of getting their crop timely reaped due to shortage of agricultural labourers. Non-availability of labor due to increased rural-urban migration. Hence, keeping these facts in view, this study was conducted to evaluate the performance of the walking behind harvester machine and introduce technology options, to minimize the cost of harvesting through farm mechanization.

## **MATERIALS AND METHODS**

The experiment was conducted at Kulumsa Agricultural Research Center (KARC) research farm near the city of Asella in 2015/16 cropping season. Wheat harvesting was performed manually with sickle and with mechanical harvester. The detailed manufacturers technical specifications of walking behind harvester used for field performance evaluation used are presented below in table 1:-



Table 1. Technical specification of vertical conveyor walking behind reaper

No.	Parameters	Specifications
1	Manufacturers	ZHEJING TING SHENG MACHINE CO. LTD.
3	Model	TNS-4S-120
4	Dimensions(L x W x H) cm	239 x 147 x 90
5	Weight (kg)	165
6	Power unit	5.5 HP single cylinder 4 stroke, air cooled, petrol start, kerosene run engine
7	Working capacity (ha/hr)	0.25
8	Crop release	Right side of the machine (viewed from rear)
9	Operating speed (km/hr)	2
10	Applicability	Dry land
11	Cutting device	Reciprocating cutter bar
12	Cutting height (cm)	10-30 from ground level
13	Cutting width (cm)	120

### Field experiment

Experimental plot size of 300m<sup>2</sup> was harvested by mechanical harvester and manual with sickle and replicated three times for each as shown in figure 1(experimental lay out). The area of the plot was measured with tape. Also randomly three small areas were selected in the plot for determining shattering loss. To calculate the operational speed of harvester, time was recorded that was taken to travel a certain distance. The distance was measured with a measuring tape and time was counted with a stop watch. Such operations were done in several times to calculate the average speed of operation. The actual field capacity was calculated by dividing the total area harvested by total time taken to harvest a certain plot. The theoretical field capacity was calculated by the formula.

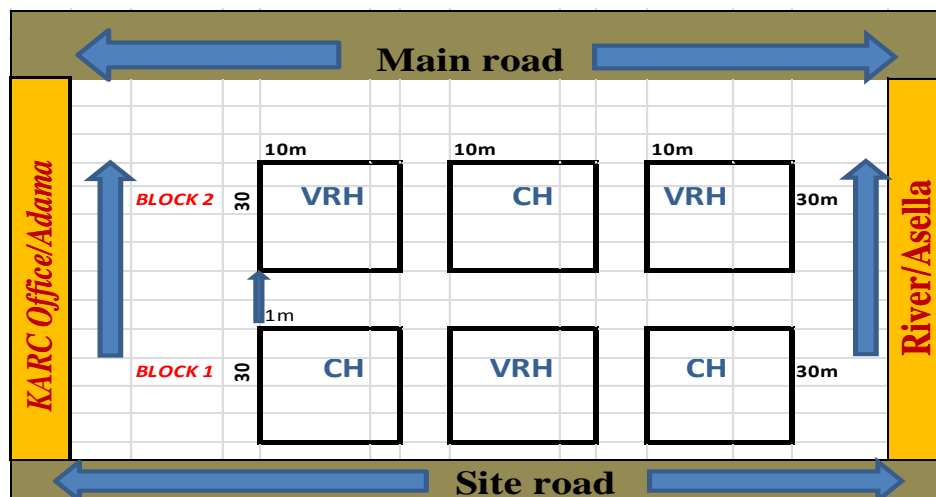

Figure 1: Experimental plot layout of wheat fields

## Performance of the Machine

### Harvesting Losses

In order to estimate harvesting losses in manual and reaper harvesting, losses that occur before harvesting (pre-harvest) was collected and measured. Harvesting losses include shattering and uncut losses were determined by the following equation (Pradhan, 1998):-

$$W_{gt} = w_{g1} + w_{g2} + w_{g3} \quad 1$$

Where:-  $W_{gt}$  = Total grain losses ( $g/m^2$ ),  $w_{g1}$  = Pre-harvest grain loss ( $g/m^2$ ),  $w_{g2}$  = Grain loss from uncut panicle ( $g/m^2$ ) and  $w_{g3}$  = Shattering grain loss (grain from cut panicle but fallen and grain loss on ground) ( $g/m^2$ )

After measuring the amount of losses at different stages, the percentage of harvesting loss was determined by the following equation (Pradhan, 1998):-

$$H_L = \frac{W_{gt} - w_{g1}}{W_{gpy}} \times 100 \quad 2$$

Where: -  $H_L$  = Harvesting grain loss (%),  $w_{g1}$  = Pre-harvest grain loss ( $g/m^2$ ),  $W_{gt}$  = Total grain losses ( $g/m^2$ ) and  $W_{gpy}$  = Potential yield ( $g/m^2$ )

### Conveying Loss

In order to estimate conveying losses in manual and reaper harvesting five sets of sample were taken using a canvass spread of 2m length on a place where cut stalks were fall. Detached grains from the panicle was collected and recorded. Percentage of conveying loss was determined by the following equation:-

$$C_L = \frac{L_C}{W_{gpy}} \times 100 \quad 3$$

Where:  $C_L$  = Conveying loss (%),  $L_C$  = Average conveying loss ( $g/m^2$ ),  
 $W_{gpy}$  = Potential yield ( $g/m^2$ )

### **Total machine loss**

After determining the amount of different harvesting losses of the machine, the percentage of total harvesting loss of the machine was determined by the following equation:-

$$T_L = H_L + C_L \quad 4$$

Where: -  $T_L$  = Total machine loss (%),  $H_L$  = Harvesting loss (%) and  $C_L$  = Conveying loss, %

### **Machine performance**

Forward speed of the machine was determined to compute the theoretical field capacity of the harvesting machine. Total operation time and lost time (turning time loss, operator personal time loss and machine adjustable time loss) during field operation was recorded to calculate the actual field capacity of the machine. The following formulas were used to compute theoretical field capacity, actual field capacity and field efficiency (R. Jaya Prakash et al, 2015).

Theoretical field capacity was calculated based on the speed of operation and cutting width of the harvester as follows:-

$$F_{CT} = \frac{W_C \times S_o}{10} \quad 5$$

Where:  $F_{CT}$  = Theoretical field capacity (ha/h)  $W_C$  = Cutting width (m) and  
 $S_o$  = Operating speed, km/h

Actual field capacity was computed based on area covered and actual time taken for covering the given area including the time lost during operation as follows:

$$F_{CA} = \frac{A_T}{T_t} \quad 6$$

Where:  $F_{CA}$  = Actual field capacity (ha/hr),  $A_T$  = Area covered during test (ha),  
 $T_t$  = Total operating time, hr

The field efficiency was obtained from the ratio of the actual field capacity to the theoretical field capacity of the machine and expressed in percent as follows:-

$$E = \frac{F_{CA}}{F_{CT}} \times 100 \quad 7$$

Where: E = Field Efficiency (%),  $F_{CA}$  = Actual field capacity (ha/h), and  $F_{CT}$  = Theoretical field capacity, ha/h

### Cost analysis

Harvesting cost of the harvester included cost of labor, machine depreciation, machine repair, fuel and lubricants. Labor cost included wages for the machine operator and the assistant operator. The harvesting cost for harvester is calculated on the basis of fixed and variable costs. The local purchase price of the reaper was 52,000birr.

### Fixed costs

Fixed cost of the machine is the cost which is involved irrespective of whether the machine is used or not. These costs include; Depreciation cost, interest on investment and taxes, shelter and insurance. Depreciation cost was calculated by straight line method. Useful life of harvester considered to be 10 years. The salvage value was also considered to be 10% of purchase price (Jannatul F. and Hajee M., 2016).

$$\text{The annual Depreciation, } D = \frac{P - S}{L} \quad 8$$

Where, P = purchase price (Birr), S = selling price (Birr), L = Useful life, yr.

Interest on Investment is an actual cost in agricultural machinery and was calculated by Straight Line Method.

$$\text{Interest on Investment, } I = \frac{P + S}{2} i \quad 9$$

Where, P = Purchase price, Birr. S = Resale value, Birr. i = annual interest rate

Shelter, Tax and Insurance cost of the machine were annually estimated as follows:-

$$\text{Shelter, Tax and Insurance, } STI = 2.5\% p \quad 10$$

$$\text{Total Fixed Cost} \left( \frac{\text{Birr}}{\text{Yr}} \right) = D + I + STI \quad 11$$

$$\text{Fixed Cost} \left( \frac{\text{Birr}}{\text{ha}} \right) = \frac{\text{Total Fixed Cost} \left( \frac{\text{Birr}}{\text{Yr}} \right)}{\text{Total Area Coverage} \left( \frac{\text{ha}}{\text{Yr}} \right)} \quad 12$$

### Variable Costs

Fuel, oil, labor, repair and maintenance cost were considered as variable costs of the machine and determined by the following formulas (Jannatul F. and Hajee M., 2016):

$$\text{Fuel Cost} \left( \frac{\text{Birr}}{\text{ha}} \right) = \frac{\text{Fuel consumed} \left( \frac{\text{Litre}}{\text{Day}} \right) \times \text{Price} \left( \frac{\text{Birr}}{\text{Litre}} \right)}{\text{Area Coverage} \left( \frac{\text{ha}}{\text{Day}} \right)} \quad 13$$

$$\text{Oil Cost, O} \left( \frac{\text{Birr}}{\text{ha}} \right) = 15\% \text{ of fuel cost, F} \quad 14$$

$$\text{Loubor Cost, L} \left( \frac{\text{Birr}}{\text{ha}} \right) = \frac{\text{Some of wages of loubors} \left( \frac{\text{Birr}}{\text{Day}} \right)}{\text{Area Coverage} \left( \frac{\text{ha}}{\text{Day}} \right)} \quad 15$$

$$\text{Repaire and Maintenanc, R \& M} \left( \frac{\text{Birr}}{\text{Yr}} \right) = 3.5\% \text{ of purchase price, P} \quad 16$$

$$\text{Total Variable Cost} \left( \frac{\text{Birr}}{\text{ha}} \right) = (\text{F} + \text{O} + \text{L} + \text{R \& M}) \frac{\text{Birr}}{\text{ha}} \quad 17$$

$$\text{Total cost of Harvesting} \left( \frac{\text{Birr}}{\text{Yr}} \right) = \text{Fixed cost} \left( \frac{\text{Birr}}{\text{ha}} \right) + \text{Variable cost} \left( \frac{\text{Birr}}{\text{ha}} \right) \quad 18$$

### Break-Even Point

The break-even point is that area in which the harvesting cost per unit area is equal for machine and manual, determined by the following equation described by Alizadeh *et al.*, (2013).

$$\text{Break - even point, B} = \frac{F}{V_a - V_m} \quad 19$$

Where, B = Break – even point (ha/year), F = Fixed costs of Machine (Birr/year)

$V_a$  = Variable costs for manual method (Birr/ha)

$V_m$  = Variable costs for machinery method (Birr/ha)

## RESULTS AND DISCUSSION

The walking behind harvester was evaluated for its performance by harvesting of wheat during 2015/16 harvesting season. The experiments were carried out in the extent of 0.18 ha at Kulumsa Agricultural Research Center of research farm. Parameters and measurements considered during this study were crop parameters, machine performance parameter, harvesting losses and cost of operations. The results of field performance based on test conducted are summarized in Table 2 and 3.

Table 2. Details of crop parameters

Particulate	Harvesting Methods				
	Mechanical harvester				Manual harvesting
	Trial		Mean value		
Crop	Wheat				Wheat
Height of plant , cm	97.2	89.6	87.9	91.6	90.2
Number of tillers per sq. m	252	243	287	261	261
Height of cut, cm	20	13	15	16	32
Condition of crop	erect	erect	erect	-	erect
Grain moisture content, %	8.9	8.6	8.7	8.73	8.73
Straw moisture content, %	8.32	8.47	8.47	8.42	8.42

Table 3: Test results of mechanical harvester compared with manual harvesting by sickle

Parameter	Harvesting Methods				Manual harvesting
	Mechanical harvester				
	Trial			Average	
1	2	3			
Actual area covered (ha)	0.03	0.03	0.03	0.03	0.03
No. of Labours	1	1	1	1	5
Total time of operation (min)	10.25	9.45	10	9.73	44.40
Effective working width (cm)	120	120	120	-	-
Forward speed (km/h)	1.95	1.78	1.88	1.87	-
Theoretical field capacity (ha/hr)	0.234	0.214	0.226	0.225	-
Actual Field capacity (ha/hr)	0.175	0.190	0.180	0.182	0.008
Field efficiency %	74.78	88.78	79.64	81	-
Labour requirement, man-hr/ha	5.69	5.25	5.56	5.5	123.33
Fuel consumption (lit/hr)	1.06	0.79	0.92	0.92	-
Fuel consumption (lit/ha)	5.83	4.33	5.08	5.08	-
Potential grain Yield (gm/m <sup>2</sup> )	533.95	482.87	606.18.	541	541
Harvesting losses (g/m <sup>2</sup> )	5.85	7.50	6.60	6.65	7.99
Harvest losses (shattering + Uncut) %	1.10	1.55	1.08	1.22	1.48

Conveying loss (g/m <sup>2</sup> )	1.10	1.19	1.04	1.11	1.37
Conveying loss, %	0.20	0.24	0.17	0.20	0.25
Total harvesting loss, %	1.30	1.79	1.25	1.42	1.73

### **Machine performance**

Measurements of harvester performance for wheat crop were the rate and quality of the machine at which the operations are accomplished. The mean value of the performance parameter that include time losses; total working time, test plot area, cutting width, cutting height, operating speed, theoretical field capacity, actual field capacity and field efficiency are shown in Table 3. The cutting width was 1.2 meter and the operating forward speed of the machine was found 1.87 km/h. The actual field capacity of the reaper for wheat crop was 0.182 ha/h. The theoretical field capacity of the machine is a function of speed of travel and cutting width and computed result is 0.225ha/h. Field efficiency of reaper harvesting machine was 81%. In manual harvesting with sickle, a laborer on average can harvest 80 m<sup>2</sup> /hr, but this amount can differ with respect to crop condition, laborer ability and weather condition. The required time for harvesting one hectare of wheat in manual harvesting was 123.33 man-h/ha compared to 5.5 man-h/ha for the harvesting (Table 3). The harvester was 22.42 times faster compared to manual harvesting.

### **Harvesting losses**

The measured values of harvesting, conveying losses and total harvesting (conveying and harvesting) losses for wheat in reaper and manual harvesting methods are presented in Table 2. The mean percentage of conveying losses in reaper and manual harvesting for wheat crop were 0.20% and 0.25% respectively and that of harvesting losses were 1.22% and 1.48% respectively. The total losses in reaper and manual harvesting were 1.42% and 1.73%. In earlier study, S.S. Karahle (2015) reported that 0.93% harvesting loss during harvesting of wheat by self-propelled reaper binder against 1.83% loss of manual harvesting.

### **Economic analysis**

The local purchase price of the reaper was 52,000birr. The annual fixed cost (7410 Birr) and variable cost (68.34Birr/h) were found from the calculation. The working hour of the reaper was considered 416 hours per year. The fixed cost and variable costs for both reaper and manual harvesting are presented in Table 3. In this study, manual harvesting required 16 man-days to harvest one hectare of wheat field. Considering the labor cost as 100Birr per day, 1600

Birr/ha was required for manual harvesting, whereas 479.01 Birr/ha was calculated for reaper harvesting (Table 3).

Net savings per hectare area as shown in Table 4, indicate that 1,251.91 Birr/ha could be saved as compared reaper harvesting against manual harvesting. This net saving comes because of higher field capacity of reaper than manual harvesting field capacity. In a previous study, net savings (1770 Bhat/ha) was found by Bora and Hansen (2007) who harvested rice by a reaper (40 Bhat = 1US\$).

Table 3: Harvesting cost of reaper and manual harvesting

Machine harvesting cost				Manual harvesting cost	
Cost items	Birr/Year	Birr/ha	Birr/hr	Birr/ha	Birr/hr
Fixed cost				1600	12.50
Depreciation	4,680	62.55	11.25		
Interest	1,430	19.13	3.44		
Taxes, insurances and shelter	1,300	17.40	3.13		
Total fixed cost	7,410	99.08	17.82		
Variable cost				1600	12.5
Fuel	14,094.08	188.35	33.88		
lubrication	2,114.11	28.25	5.08		
labor	10,400	139	25		
Repair and maintenance	1,820	24.33	4.38		
Total variable cost	28,428.19	379.93	68.34		
Total cost of harvesting	35,838.19	479.01	86.16	1600	12.5

Table 4: Comparison of savings by the reaper harvesting per hectare

Particulars	Calculation	Amount (Birr)
Cost of manual harvesting (16 man-days/ha)	16×100	1600
Cost of machine harvesting/ha	479.01	479.01
Gross savings	1600 – 479.01	1,120.99
Cost of total output (5400 kg/ha @ 8 birr/kg)*	8×5400	43,200
Loss in reaper harvesting, (1.42%)	43,200 ×0.0142	613.44
Loss in manual harvesting (1.73%)	43,200 ×0.0173	747.36
Excess loss due to manual harvesting	747.36 – 613.44	133.92
The net savings per hectare	1,120.99 + 133.92	1,251.91

\*Considered the production of wheat 54 quintal per hectare

### Break-even Point Analysis

Harvesting cost by a reaper is found to be decreased gradually with the increase of harvesting area. However, break-even point is 6 ha of land where same cost will be found for both of reaper and manual harvesting. This break-even point indicates that reaper would be beneficial to the farmers when the area of the harvesting land is more than 6 hectare of land per year.





## SUMMARY AND CONCLUSIONS

Based on the field performance evaluation harvester conducted during harvesting season of 2016/17, it can be summarized as follows:-

The average effective field capacity and field efficiency of the reaper was found to be 0.182 ha/h and 81% respectively whereas the effective field capacity in manual harvesting was 0.008 ha/h. Fuel consumption of the reaper was 0.92 lit/h, 5.08 lit/ha. Average value of harvest losses in mechanical harvesting was 1.42 percent only whereas average value of harvesting losses in manual harvesting was 1.73% which is more than that of mechanical harvesting.

The cost of harvesting for reaper harvester and for manual harvesting were 479Birr/ha and 1600Birr/ha respectively. The percent saving in the cost of harvesting is reduced by 30% harvesting of wheat with reaper harvester over manual harvesting. For economic justification of machine application, the yearly capacity of machine must not be less than 6ha/year. It can be conclude that, the use of harvesting is much more economic and efficient for harvesting of wheat compared to manual harvesting method. Therefore in fields where the use of walking behind harvester is possible, it will play an important role in reducing production costs.

## REFERENCES

- Alizadeh, M. R. and A. Allameh. 2013. Evaluating rice losses in various harvesting practices. *International Research Journal of Applied and Basic Sciences* 4 (4): 894-901.
- Bora, G. C. and G. K. Hansen. 2007. Low Cost Mechanical Aid for Rice Harvesting. *Journal of Applied Sciences* 7 (23):3815-3818.
- Jannatul F. and Hajee M., 2016. Study on Performance Evaluation of Self-propelled Reaper. *Proceedings of the 2016 International Conference on Industrial Engineering and Operations Management Kuala Lumpur, Malaysia, March 8-10, 2016.*
- R. Jaya Prakash, B. Ashwin Kumar, G. Aravind Reddy and K.Y.S. Rami Reddy, 2015. Performance evaluation of reaper-binder in rice crop. *International Journal of Agricultural Engineering* 8(2)
- Pradhan, S.C., R. Biswajit, D.K. Das and M. Mahapatra, 1998. Evaluation of various paddy harvesting methods in Orissa. India. *AMA*, 20: 35-38.
- Singh, L. P. K. K. Jain, V. R. Vagadia and A. H. Memon, 2008. Evaluation and Improvement in Design of Self Propelled Vertical Conveyer Reaper. *Agricultural mechanization in Asia, Africa, and Latin America*, 39(2).
- S.S. Karahle, A. V. Gajakos, P. S. Neharkar, S. R. Kamdi and S. P. Lambe, 2015. Performance Evaluation of Self-propelled Reaper Binder. *International Journal of Tropical Agriculture* 33(2): 0254-8755.2 – 238.232-

## **Evaluation of Soybean Thresher for Chickpea Crop**

Ashebir Tsegaye\*, Abulasan Qabaradin, Getachew Hailu

Oromia Agricultural Research Institute, Asella Agricultural Engineering Research Center

P.O. Box 06 Assela Ethiopia E-mail: [tsegayeeashebir@gmail.com](mailto:tsegayeeashebir@gmail.com)

### **Abstract**

*The present study was conducted in view to optimize important operational and crop parameters influencing the threshing of chickpea seed crop. Drum speed and feed rate were taken as independent parameters and threshing efficiency, cleaning efficiency and visible grain damage were studied as dependent parameters. Drum speed was found the most critical factor for affecting threshing efficiency, cleaning efficiency and visible grain damage. With increasing drum speed in the range of 500 to 700 rpm, threshing efficiency increased from 83.95 to 93.54%, cleaning efficiency increased from 69.21 to 79.93% and grain damage increased from 2.35 to 2.94%, while increasing feed rate threshing efficiency, cleaning efficiency and grain damage decreased. Hence, the recommended treatment combination was 700rpm and 15kg/min at mean moisture content of 11.5%, as amongst the selected treatment the threshing capacity and threshing efficiency was maximum. At this combination the percentage of threshing capacity, threshing efficiency, cleaning efficiency and grain damage were 443.2kg/hr, 95.05%, 74.65% and 3.71% respectively.*

**Key words:** *thresher, performance, threshing efficiency, cleaning efficiency and grain breakage.*

### **INTRODUCTION**

The pulse production has remained relatively stagnant and the crop area has declined substantially in Ethiopia. Stagnant production and growing demand have led to rising pulse prices. Chickpea and haricot bean is the most important pulse crop of Ethiopia. Chickpea (*Cicer arietinum L.*) is the most important food legume for direct consumption in the world. Chickpea is produced in a range of crop systems and diverse environmental regions (FAO, 1999). The successful production and good marketability of these crops depend on both quantity and quality of the crop. To increase seed production with good quality feasibility of

threshing machine must be for chickpea seed threshing and selecting the optimum operating conditions. Chickpea seed being dicotyledonous which is makes it prone to mechanical injuries.

Traditionally, chickpea is threshed by trampling animals on a prepared threshing ground which is labour intensive, tedious and time consuming. Commercially available mechanical threshers are mainly for paddy and wheat etc. Thresher for podded pulse crops, like chickpea, haricot bean, cowpea, field pea and soybean etc. has not yet been commercialized. Hence, researchers made attempts to use commercially available paddy threshers with wire loop cylinder (Devnani, 1976), wheat threshers with rasp bar or peg tooth cylinder (Kulkarni and Singh, 1986) and axial flow thresher with peg tooth cylinder as dual or multicrop thresher to thresh chickpea, haricot bean and other pulse crops (Majumdar, 1985). But significant amount of visible damages were observed. However, reduction in visible damage was observed with changing the operational parameters of threshing.

Hence, in light of above facts, this study was undertaken with objective to study and optimize important operational conditions influencing the threshing efficiency and quality of chickpea seed crops.

## **MATERIALS AND METHODS**

### **Plot thresher**

Locally made plot thresher (Fig. 1) was taken for the study. It consists of wire loop type drum, concave, separating and cleaning unit. The drum consisted of total 32 wire loop, placed at 52 mm apart in staggered arrangement among six rows. Diesel engine of 10 hp, was used as power source. The power from engine is transmitted to threshing drum and cleaning system by set of V-belt and pulley arrangement.



Figure 1. A view of plot thresher at experimental site

### Crop

Chickpea (*Cicer arietinum L.*) was taken for the study. Field experiments were carried out for threshing of chickpea crop in a private farm in Tiyo wereda during planting season of 2015. All experiments were conducted using plot threshing machine.

### Performance of the machine

The performance of the machine was evaluated in terms of threshing capacity (kg/hr), percentage of grain breakage (%), threshing efficiency (%) and cleaning efficiency (%) using the following equations;

$$\text{Threshing capacity (Kg/hr)} = \frac{W}{T} \quad 1$$

Where:- W = Weight of threshed grains (kg),

T = Time consumed in threshing (h)

$$\text{Percentage of grain brakege (\%)} = \frac{B_g}{T_g} \times 100 \quad 2$$

Where:- B<sub>g</sub> = Broken grain (Kg),

T<sub>g</sub> = Total weight of sample grain taken from main outlet (Kg)

$$\text{Threshing efficiency, \%} = \frac{T_g - U_g}{T_g} \times 100 \quad 3$$

$$\text{Cleaning efficiency, \%} = \frac{W}{W_o} \times 100 \quad 4$$

Where: -  $U_g$  = Weight of un threshed grains (Kg),

$W$  = Weight of grains from the main output opening after cleaning, (Kg),

$W_o$  = Weight of grains and small chaff from the main output opening, (Kg).

### **Design of experiment and analysis of data**

The performance tests of the plot thresher was conducted for chickpea crop at different three levels of drum speeds and three levels of feed rates by using randomized block design (RBD) of a 3x3 factorial experiments with three replications in each treatment and comparison between treatment means by least significance difference (LSD) at 5% level.. The drum speeds of 500, 600 and 700 rpm and feed rates of 5, 10 and 15 kg/min were considered for experiment at moisture content of 11.5 % ( db).

## **RESULTS AND DISCUSSION**

The performance of the thresher is discussed in this chapter. The performance of the thresher was evaluated at various drum speed and feed rate at constant moisture content of 11.5% for chickpea in terms of threshing capacity, threshing efficiency, cleaning efficiency and percentage of grain breakage.

### **Threshing capacity**

The effect of drum speed and different levels of feed rate on grain throughput capacity are given in figure 2. The result shows that, the throughput capacity of the machine tend to increase with the drum speed and level of feed rate. The higher the feed rate and at an increase in speed, throughput capacity increases. A high throughput capacity of 443.2kg/hr was

obtained at the highest speed of 700rpm and highest feed rate of 15kg/min. The value of feed rate in figure 1 indicates that there is a close relationship with grain throughput capacity. The  $R^2$  values for all levels of feed rate indicate that there is a close relationship between the speed and the grain throughput capacity.

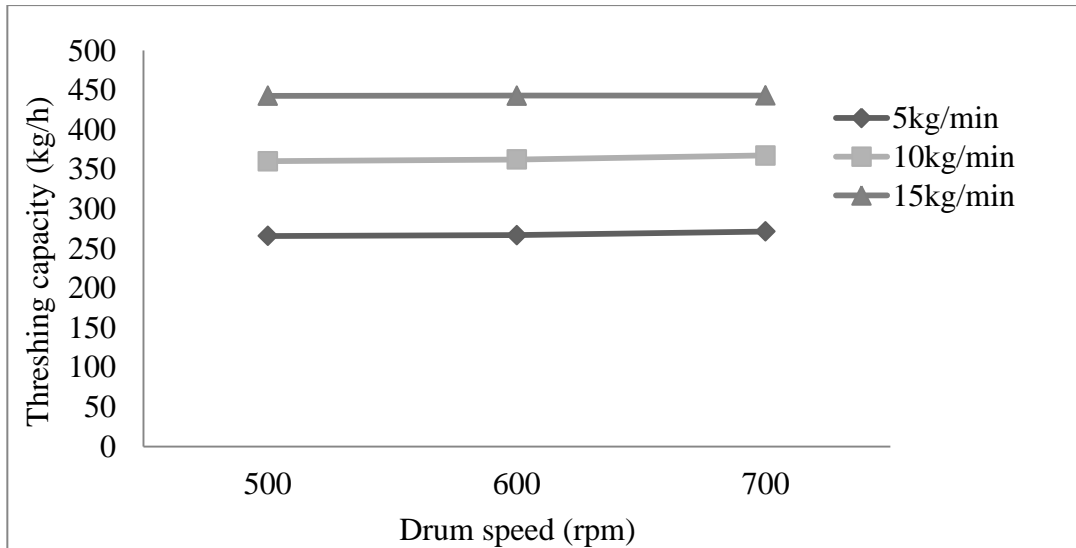

Fig. 2. Effect of drum speed on threshing capacity at various feed rate

### Threshing efficiency

The values of percent threshing efficiency at different drum speeds and feed rates have been plotted in Fig.3. From the figure, it is clear that increasing the drum speed from 500 to 700 rpm increased the threshing efficiency from 85.90 to 93.54, 85.43 to 93 and 83.92 to 92.87 % at feeding rates 5, 10 and 15 kg/min, respectively and constant grain moisture content of 11.5% of crops. The effect of drum speed was significant at 5 percent level of confidence (Appendix table 1.1). However, the interaction of drum speed and feed rate was not-significant. Minimum threshing efficiency (83.92 per cent) was observed at drum speed of 500rpm and feed rate of 15kg/min, while the maximum threshing efficiency was (93.54 per cent) observed at drum speed of 700rpm and feed rate feed rate of 5kg/min. Threshing efficiency has direct and inversely relationship with drum speed and feed rate, respectively. This finding agrees with that of Zaalouk (2009) who reported the same trend for haricot bean thresher. Baldev *et al.* (2014) reported that, threshing efficiency was directly proportional to peripheral speed of threshing drum and negatively correlated with the feed rate.



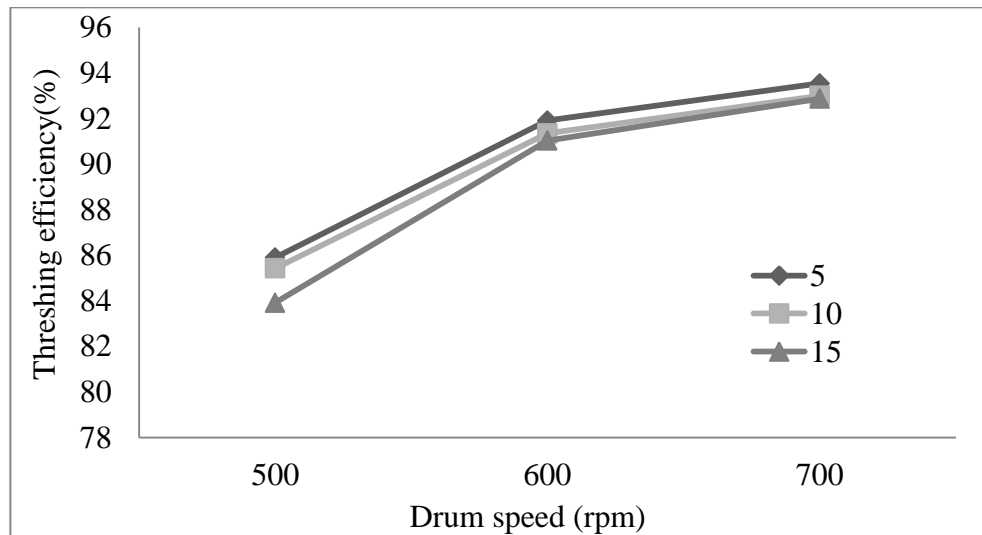

Fig. 3. Effect of drum speed on threshing efficiency at various feed rate

### Cleaning efficiency

The effect of three levels of drum speeds and feed rates on cleaning efficiency was studied. The values of percent cleaning efficiency have been plotted on Figure.4. The data for cleaning efficiency was also statistically analyzed. Effect of drum speed was found significant (Appendix table 1.2) at 5 percent level of confidence. However, effect of feed rate and the interaction effect of drum speed and feed rate were not significant. It was revealed that the percent cleaning efficiency ranged from 69.21 to 79.93 at 500rpm and 15kg/min and 700rpm and 5kg/min, respectively (Fig.4). Cleaning efficiency has direct relationship to the drum speed, i.e. with the increase in the drum speed the cleaning efficiency increased, and it decreased with the increase in feed rate. The cleaning efficiency increased with increase in drum speed as the threshing drum and blower were driven by threshing drum. Hence, increase in the speed of threshing drum increased the material other than grain separation. Further, cleaning efficiency decreased with the increase in feed rate, as at higher feed rates, frequent choking occurred. Baldev *et al.* (2014) reported that, the same trends of cleaning efficiency is directly related to the peripheral speed, i.e. with the increase in the peripheral speed the cleaning efficiency increased, and it decreased with the increase in feed rate.

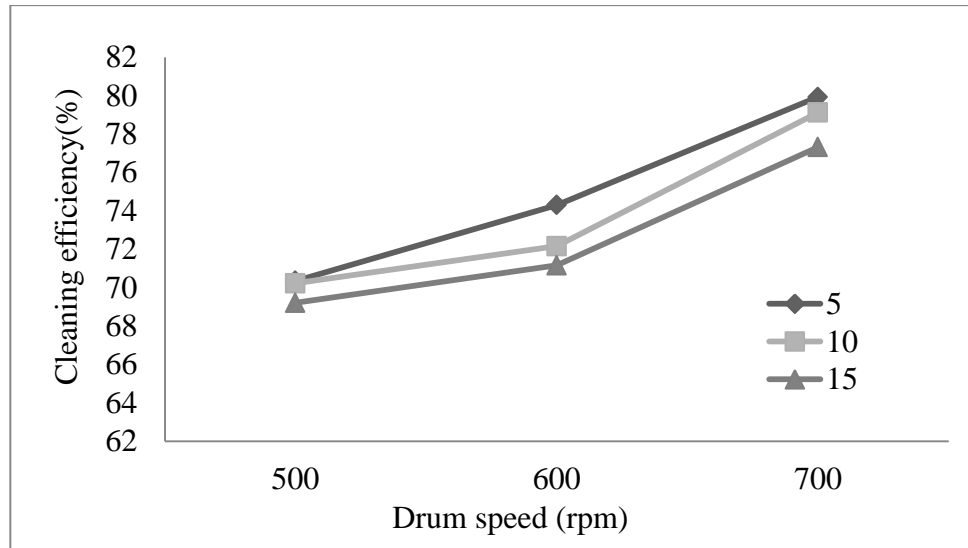

Figure 4. Effect of drum speed and feeding rate on cleaning efficiency

### Percentage of grain breakage

The effect of three levels of drum speeds and three levels of feed rates was studied on grain breakage. The percentage breakage at different drum speeds and crop feed rate is shown in Figure 5. The result clearly indicated that grain breakage was directly related to the drum speed and inversely related to material feed rate. The effect of drum speed on percentage of grain breakage was significant at 5 percent level of confidence (Appendix table 1.3). However, the effect of feed rate and their interaction on percentage of grain breakage was not significant. The percentage of grain breakage ranges from 2.35 to 2.94. The minimum breakage of 2.35% was obtained at lower drum speed (500rpm) and higher feed rate (15 kg/min), while maximum breakage of 2.94% was at higher drum speed (700rpm) and lower feed rate (5 kg/min). Zaalouk (2009) reported that increasing the drum speed from 11.72 to 15.38 m/s increased the seed damage from 2.40 to 2.90, 1.95 to 2.51 and 1.89 to 2.17 % at different feed rates of 10, 15 and 20 kg/min respectively and at constant grain moisture content of 10.5%. Breakage was found to be higher at higher drum speed due to higher combined effect of impact and rubbing force (Neeraj and Singh, 1988).

The breakage was also more at lower feed rate due to higher impact of threshing members. The common cause of damage in grain mechanical handling is the particle velocity and rigidity (Paulsen, 1978 and Paulsen *et al*, 1981). Anwar and Gupta (1990) reported that the percentage

of grain damage increased with an increase in drum speed for all feed rates and the mean grain damage decreased with increasing feed rate. Baldev *et al.*(2014) found that, the minimum breakage of 0.64 per cent was observed at lower peripheral speed (16.4m/s) and higher feed rate (1000 kg/h), while breakage was the maximum at higher peripheral speed (21.9m/s) and lower feed rate (700 kg/h).

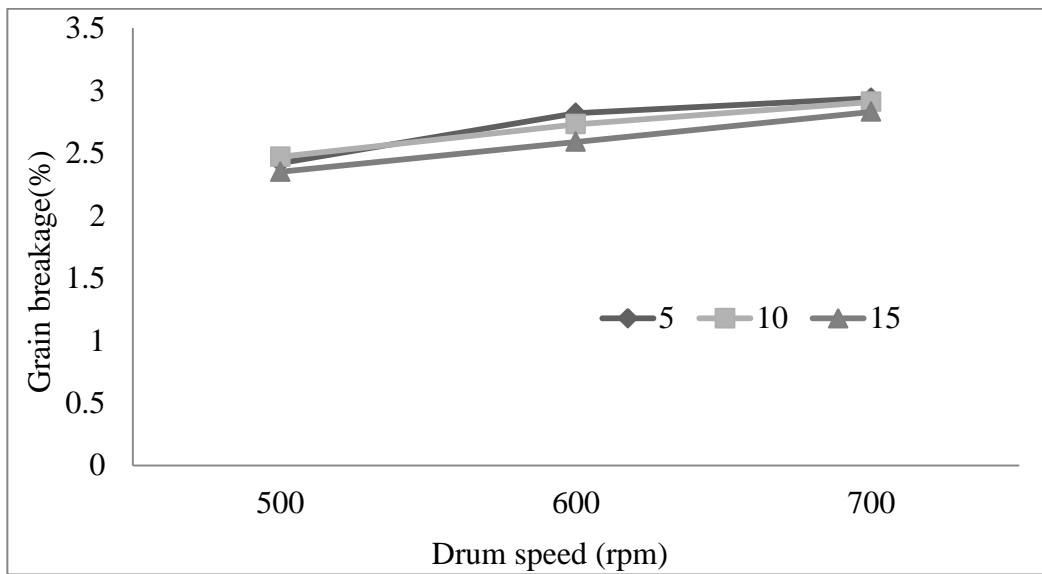

Fig.5. Effect of drum speed and feeding rate on percentage of grain breakage

### SUMMARY AND CONCLUSION

The effect of drum speed and feed rate on dependent variables *viz.*, threshing efficiency, cleaning efficiency and grain breakage was studied. To obtain optimum combination of parameters the criteria adopted was that the threshing efficiency and cleaning efficiency should be the maximum and percentage of breakage should be at recommended level.

Drum speed and feed rate play an important role in threshed seed quality of chickpea. Drum speed has a significant effect on threshing efficiency, cleaning efficiency and percentage of grain damage, while feed rate has a significant effect on threshing efficiency only. Test results indicate that drum speed was found the most critical factor that affecting threshing efficiency, cleaning efficiency and percentage of grain damage. With increasing drum speed from 500 to 700 rpm, threshing efficiency increased from 83.95 to 93.54%, cleaning efficiency increased

from 69.21 to 79.93% and percentage of grain damage increased from 2.35 to 2.94%, while increasing feed rate threshing efficiency, cleaning efficiency and percentage of grain damage decreased. Analysis of ANOVA revealed that the effect of drum speed on threshing efficiency, cleaning efficiency and percentage of grain damage was significant at 5 percent level of confidence (Appendix table 1). However, effect of feed rate and the interaction of drum speed and feed rate were not-significant. Kepner *et al.* (1992) reported that four factors are very important when threshing is considered; these factors includes the peripheral speed of the cylinder, the clearance between cylinder and concave, crop maturity and the feed rate. Hence, the recommended treatment combination was 700rpm and 15kg/min at mean moisture content of 11.5%, as amongst the selected treatment the threshing capacity and threshing efficiency was maximum. At this combination the percentage of threshing capacity, threshing efficiency, cleaning efficiency and grain damage were 443.2kg/hr, 95.05%, 74.65% and 3.71% respectively. Baldev (2014) reported, drum speed of 18.2 m/s and feed rate of 1000 kg/h resulted in optimum percentage of threshing efficiency and cleaning efficiency and minimum percentage of grain breakage.

### **Recommendations**

From the analysis and discussions of the performance result of the test on the soybean thresher and in order to improve on the performance, the following recommendations should be considered;

1. To improve on the threshing capacity concave clearance, hopper inlet opening mechanism should be improved.
2. To improve on the grain damage the drum page should be rubber coated to reduce grain damage.

## REFERENCES

- Ajayi, O. A. (1991). Design of threshing for locust bean, AMA 22 (3): 21-24.
- Anwar, M.T. and G. P. Gupta. (1990). Performance evaluation of chick pea thresher in Pakistan AMA 21 (5): 23-28
- Ajayi, O. A. (1991). Design of threshing for locust bean ,AMA 22 (3) : 21-24.
- Baldev Dogra, Ritu Dogra\* , Saravjeet Singh and Gursahib Singh Manes (2014). Performance of modified spike tooth thresher for pigeonpea (*cajanus cajan*). *Legume Res.*, 37 (6) : 628-634.
- Bernard, Richard L. "Soyabean," Microsoft ® Encarta ® Encyclopedia 2007[CD]. Redmond, WA: 1 Microsoft Corporation, 2006.
- Devnani R S (1976) Development of pulse crop threshers. Annual Report 1975-76 College of Technology and Agril Engg, Udaipur.
- FAO (1999). Phaseolus bean: Post-harvest Operations.
- Kaul, R. N. and C. O. Egbo (1985): Introduction to Agricultural Mechanization. First edition. Macmillan Education Ltd. London.
- Kulkarni S D and Singh G (1986) Performance of wire loop cylinder for gram. Journal of Institution of Engineers 67: 24-26.
- Majumdar K L (1985) Design, development and evaluation of CIAE multicrop thresher. Proc. Silver jubilee convention of ISAE. pp 28-32. Bhopal.
- Neeraj and Singh B (1988) Performance evaluation of Pigeonpea (*Cajanus cajan*) threshing mechanism. *J. Agric Engg* 25 (4): 9-17.
- Paulsen, M. R. (1978). Fracture Resistance of Soybeans to Compressive Loading. *Trans. ASAE*, 21: 1210-1216.
- Paulsen M R, Nave W R and Gray L E (1981) Soybean seed quality as affected by impact damage. Transactions of the ASAE 24 (6): 1577 -11589.
- Salari K., Amiri R., Chayjan, Khazaei J. and Amiri Parian J.(2013). Optimization of Independent Parameters for Chickpea Threshing Using Response Surface Method (RSM). *J. Agr. Sci. Tech. Vol. 15: 467-477*
- Sinha J.P., Dhaliwal I. S, Sinha S .N. and Anoop Dixit "Studies on Machine-Crop Parameters for Chickpea Seed Crop Threshing" Agricultural Engineering International: the CIGR Ejournal. Manuscript PM 07 026
- Zaalouk A. K.(2009). Evaluation of Local Machine Performance for Threshing Bean. *Misr J. Ag. Eng.*, 26(4): 1696 – 1709.

## Appendix

### Appendix 1. Analysis of Variances

Appendix Table 1.1 Analysis of variance (RBD) of threshing efficiencies

Source of variation	d.f.	s.s.	m.s.	v.r.	F pr.
Replication	2	5.833	2.917	0.81	
Drum speed (DS)	2	368.926	184.463	51.31	<.001
Feed rate (FR)	2	0.649	0.325	0.09	0.914
DS*FR	4	8.095	2.024	0.56	0.693
Residual	16	57.516	3.595		
Total	26	441.020			

Appendix Table 1.2 Analysis of variance (RBD) of cleaning efficiencies

Source of variation	d.f.	s.s.	m.s.	v.r.	F pr.
Replication	2	43.704	21.852	2.93	
Drum speed (DS)	2	373.095	186.547	24.99	<.001
Feed rate (FR)	2	19.833	9.917	1.33	0.293
DS*FR	4	8.603	2.151	0.29	0.881
Residual	16	119.439	7.465		
Total	26	564.674			

Appendix Table 1.3 Analysis of variance (RBD) of percentage of grain breakage

Source of variation	d.f.	s.s.	m.s.	v.r.	F pr.
Replication	2	0.050987	0.025493	4.47	
Drum speed (DS)	2	1.051898	0.525949	92.20	<.001
Feed rate (FR)	2	0.099545	0.049772	8.72	0.003
DS*FR	4	0.024613	0.006153	1.08	0.400
Residual	16	0.091274	0.005705		
Total	26	1.318316			

# Characterization and Redesigning of Mada Batu Small Scale Irrigation Scheme, West Arsi Zone of Oromia Region

Bayan Ahmed

Oromia Agricultural Research Institute, Asella Agricultural Engineering Research Center  
P.O. Box 06, Asella, Ethiopia  
Email: [bayahm@gmail.com](mailto:bayahm@gmail.com)

## Abstract

*Irrigation enhances agricultural production, improves the food supply and income of rural population in Ethiopia. From this important viewpoint irrigation projects were widely studied, planned and implemented throughout the country. However, little or no attention was given to the monitoring and evaluation of the performance of already established schemes. The aim of this study was to characterize and redesign of Mada-Batu small scale irrigation scheme in order to improve the performance of the irrigation system. Firstly, scheme was characterized in terms of capacity, dimensions and functionality of reservoir, main and secondary canal and then redesign of the scheme was done depending on the current command area of the scheme. The scheme has trapezoidal shape of reservoir with a capacity of 2604 m<sup>3</sup> live storage along with trapezoidal shape of main canal with average size of 161, 59, 38.2 cm at the top, bottom and depth respectively and maximum discharge capacity when gate was fully opened at off take was 70 l/sec. The overall efficiency of the scheme is rated at reasonable category. The current redesigned capacity of main canal was 524 l/s and dimensions of 253.9, 74 and 60 cm at the top, bottom and depth respectively.*

**Key words:** *small scale irrigation scheme, characterization, command area, redesigning*

## INTRODUCTION

Ethiopia has total area coverage of 1.13 million km<sup>2</sup>, of which 99.3 percent is a land area and the remaining 0.7 percent is covered with water bodies of lakes (MoWR, 2002). The agricultural sector is the leading sector in the Ethiopian economy, 37.2 percent of the total GDP, as compared to 21.3 percent from industry and 41.5 percent from services (CAI, 2016). Though agriculture is the dominant sector, most of Ethiopia's cultivated land is under rain fed agriculture. Due to lack of water storage and large spatial and temporal variations in rainfall, there is no enough water for most farmers to produce more than one crop per year and hence there are frequent crop failures due to dry spells and droughts which have resulted in a chronic food shortage currently facing the country (Seleshi *et al.*, 2007).

Irrigation is one means by which agricultural production can be increased to meet the growing demands in Ethiopia (Seleshi *et al.*, 2005). According to Robel (2005) also indicated that one of the best alternatives to consider for reliable and sustainable food security development is expanding irrigation development on various scales, through river diversion, constructing micro dams, water harvesting structures, etc. The development of irrigation and agricultural water management holds significant potential to improve productivity and reduce vulnerability to climactic volatility in any country (IWMI, 2010).

Considering the current Ethiopian situation with growing population pressure in the highland areas and a rapidly declining natural resource base has necessitated irrigated agriculture and in line with this irrigation is given prime attention on the country's development agenda. The irrigation potential of the country is estimated to be about 3.7 million hectares. Of the total potential, only about 20 to 23% of this potential is put under irrigated agriculture (both traditional and modern irrigation systems) (NRMD, 2011).

Performance evaluation for any irrigation system is essential to assess how far the goals and objectives set forth at the time of project formulation of the system have been achieved. This is a useful tool to provide necessary feedback for improving the systems management by initiating remedial measures (Rani *et al.*, 2011). The performance evaluation conducted on 26 existing small scale irrigation schemes in south region of the country and identified the majority of them under failing and performing below their capacity (Robel, 2005). Identifying the areas in which they fall short of their potentials is essential. To this effect, it is important to measure and evaluate their success or failure objectively and identify specific areas that need improvement. Hence, reliable measures of the system performance are extremely important for improving efficiency and management decisions. One of such scheme selected for this study to identify the major problem and its performance capacity is Mada-Batu Irrigation Scheme.

The Mada Batu small scale scheme is one of small scale irrigation scheme that was designed to serve limited household of the area but as the population near irrigation scheme was increasing, the farmers were extending their farm land out of designed command and since the



scheme was serving for more than 39 years, the reservoir capacity was decreasing due to flood from town deposited sediment to reservoir and the main canal was cracked by tree root at different place results water loss. For these reason commands area and water supply of the scheme was not matching even if a water source is good. According to Bayan (2017) performance evaluation conducted on the scheme, the main canal had conveying 70 l/s which are sufficient to irrigate 103 ha of land but current the commend area are 385 ha. Additionally conveyance efficiency ( $E_c$ ), application efficiency ( $E_a$ ) and overall efficiency ( $E_o$ ) were 64.77, 64.54 and 41.47% respectively. According to FAO (1989) the overall efficiency of the scheme was fall under interval of the reasonable and most of secondary and tertiary canals were not functional, due to this farmers' diverted water to their own way from division box reaching to their farms. This results in scarcity of water and lead to conflict between the farmers. Hence, this study was made to characterize and redesign the Mada Batu irrigation scheme.

## **MATERIALS AND METHODS**

### **Description of the study area**

Mada Batu small-scale irrigation scheme was located in Gedeb Asasa district; West Arsi zone of the Oromia Region. It has a latitude  $38^{\circ}57'3''W$ - $39^{\circ}25'51''E$  and longitude of  $7^{\circ}21'49''N$ - $7^{\circ}1'28''S$  with average elevation range 2200 to 4180 m.a.s.l. This district is situated on Addis Ababa to Bale road at a distance of 285 km and 110 km from Asella town. The minimum and maximum temperature of the district is found between 12 -  $25.3^{\circ}C$  and annual mean rainfall 995.6 mm.

### **Data collection**

The study was conducted during off season from December 2015 to May, 2016 when the crops being cultivated under irrigation. Three locations were selected along the scheme for canal characterization. During the study period regular visit, observations and the primary and secondary data were collected. The primary data such as characterization of irrigation scheme continues spring discharge measurement and scheme soil texture. For analysis of soil texture 54 soil samples were collected from farmers' fields. The secondary data collected were meteorological data from National Metrological Agency and the history of the irrigation

scheme from West Arsi Zone and Gedeb Asasa district offices of irrigation development authority.

### **Characterization of irrigation scheme**

The characterization of the scheme was done by field observation and dimension measurements of its reservoir and canals. The reservoir, main and secondary canals were described in terms of their discharge, dimensions and functionality of the scheme elements. Since the reservoir had trapezoidal shape, determination of reservoir capacity was done according to Michael and John (1991) stated for pond capacity calculation of trapezoidal. The top and bottom dimension of dead and live storage were observed and measured. The live storages were measured by closing the night storage at night time and the depth of the water were measured at 24 places at interval of ten meters. The dead storages of the reservoir were also measured by releasing water from the reservoir and the depths of dead storage were taken at 10 place of reservoir at interval of ten meters. Finally the live storage and dead storage were calculated by multiplying individual area with average depth of live and dead storage respectively. Then total reservoir storage was estimated by adding live storage with dead storage. The canal dimension was measured at bottom, top and depth of canal by metering tape at different places.

### **Determination of crop and irrigation water requirements**

Crop and irrigation water requirements were determined using CROPWAT computer program.

### **Redesigning the Scheme**

#### **Hydrological analysis**

Since the spring water was used for irrigation purpose, continuous discharge of flow from the reservoir was measured at different time by Area Velocity Method using current meter at its out let. This continuous discharge at different time was averaged and design of reservoir capacity was determined depending on this discharge.

### **Cropping pattern**

The irrigation period was started from November to May and the rest months are cultivated by rain. Generally, cropping pattern for the scheme has been considered based on farmers experience in the study area for many years to determine the crop water need at command area. For this four crop types (potato, garlic, carrot and cabbage) were identified.

### **Irrigation duty**

The amounts of water applied to command area continuously for the entire base period of the crop were determined using the CROPWAT.

### **System design capacity**

#### **Soil type and canal type design**

Due to costs of construction, water management and maintenance was simple than other canal type, trapezoidal shaped canal were selected. The soil textural class of the irrigation scheme was determined in laboratory and after analysis it was identified using USDA textural triangle, then the assumed design parameters were determined based on identified soil type. Accordingly, redesigning of conveyance system was done using manning equation as stated in equation (1)

$$Q=1/n*A*R^{2/3}S^{1/2} \quad 1$$

In which, Q = Discharge (m<sup>3</sup>/s)

A= Area of cross-section of flow (m<sup>2</sup>)

R = Hydraulic radius (m) which is A/P. Here, P is the wetted perimeter in (m)

n = Manning's coefficient, and

S = Slope gradient (m/m).

Parameters, like maximum allowable flow velocity (i.e., which not cause scouring), manning's roughness coefficient (n) and channel bed slope was assumed depending on soil type and area condition from standard recommended value.

### **Canal design procedures of manning formula**

Step 1. Discharge (Q), maximum permissible velocity (V), Manning's n, bed slope (S), and side slope (k: 1) are given or have been assumed.

- Step 2. Determine the area of cross section from the continuity equation
- Step 3. Determine the hydraulic radius, R, from the Manning's formula
- Step 4. Determine the wetted perimeter from the relation,  $P = A/R$
- Step 5: Determine the depth D and bed width B from the values of A and P obtained.
- Step 6. Adding free boards

## **RESULTS AND DISCUSSION**

### **Characterization of the Irrigation Scheme**

Mada Batu irrigation scheme was established by Ethio-Korean government at the end of 1977 E.C. During the establishment, the scheme was designed to irrigate 200 ha of land. The source of water to irrigate scheme was spring water and has one reservoir, which store's water at night time and supplied to field during day. At rainy season, the gate of reservoir is left open because the farmers use rain water. When the rains pass, the reservoir gate is closed to store water for irrigation.

### **Soil texture**

From Table 1 the textures of the soil in the three study fields of irrigation scheme fall under loamy soil in all land surface of command area under study. This soil is suitable to grow almost all crops.

Table 1. Laboratory result of soil textural class of Mada Batu irrigation scheme

Soil properties	Soil sampling location		
	US	MS	LS
% sand	43	43	48
% silt	30	33	28
% clay	28	24	24
Texture class	Loam	Loam	Loam

US=upper stream MS=Middle stream LS=Lower stream

### **Reservoir storage**

The reservoir storage of the scheme was made from earthen dam. It was having trapezoidal shape and had two off takes gate. The first one was having regulated discharge from reservoir to the main canal and the second one was used to discharge excess water from the reservoir. During rainy season when there was high rain, flood collected from town over top drainage

canal of the road and flooded to the reservoir. This results in sediment deposition to the reservoir. This was one of the sources for low level of main canal capacity. Currently the capacity of the reservoir is 2604 and 564.3 m<sup>3</sup> live and dead storage respectively giving total reservoir storage capacity of 3168.3 m<sup>3</sup> (Table 2).

Table 2. Reservoir dimension and its capacity

Shape	Top width (m)	Bottom width (m)	Average water depth (m)	Area (m <sup>2</sup> )	Reservoir length (m)	Volume (m <sup>3</sup> )
(1)	(2)	(3)	(4)	(5)=(0.5*(2+3))*4	(6)	(7=5*6)
A1	42.00	28.00	1.55	54.25	48.00	2604.00
A2	28.00	26.00	0.55	14.85	38.00	564.3
<b>Total</b>						<b>3168.3</b>

$A_1$ =Reservoir area of live storage  $A_2$ =Reservoir area of dead storage

### Main canal

It was of trapezoidal shape of canal that some parts were lined and others were unlined. The main canal starts from reservoir and convey water for secondary canal and electrical motor pump. It had different dimensions at different place but having the average of 161 cm top width, 59 cm bottom width and 38.2 cm depth. The maximum discharge capacity of the main canal measured when gate was fully opened during the study time at off-take, upper, middle and lower stream were 70, 62, 41, 33 l/sec respectively. From field observation, the main canal section was grass vegetated, bank was eroded, and some part of canal was cracked by trees. These are the main reason for water losses along the canal. This canal currently irrigates 330 ha of farmers land even though it was initially designed to supply for 200 ha.

### Secondary canal

Most of the secondary canals of the scheme were found at middle and lower side of study area. At lower side of scheme existing electrical motor pump was damaged; most of secondary canals were also not functional. Instead of electrical motor pump, the farmer of the right side use individual motor pump to irrigate their farm. Upper site get water from main canal via division box constructed near main canal. Some farms that far from main canal have secondary canals but they were not used due to the fact that some components like water closing gate and

division box were damaged. Due to non-functionality of secondary canal, the farmers divert water to its own way from division box reached their farm.

### **Redesigning the scheme**

The redesign of the scheme is needed due to the current command area and water supply demand of the scheme was not matching. According to Gedeb Asasa irrigation development authority, the scheme was designed to irrigate 200 ha of land but currently farmers were expanded the farm by taking water from the canal by motor pump and as a result the command area is increased to 330 ha. Since the scheme has been serving for more than 39 years, the reservoir capacity was decreasing due to sediment deposition to reservoir. It can only take eleven hour to fill the reservoir. Thus, the lower side of the scheme about 55 ha of land of command area was not getting water completely. The command area suitable for irrigation was 385 ha when the canal water supply is modified. That is why; the redesign of the scheme was need.

### **Scheme water requirement**

Crop water requirement was determined using CROPWAT computer software for major crops irrigated (i.e., potato, garlic, carrot and cabbage) in the area. The output of the model for scheme irrigation requirements of four crops in the command area was shown in Table 3. From this table the highest gross scheme water requirement for those crops in this cropping season was observed in the months of February as 261.8 l/s. So, this is taken as a peak discharge which determines the designs of canal.

Table 3. The four crop patterns in study area

Crop type	Irrigation requirement	Dec	Jan	Feb	Mar	Apr	May
Crop pattern	Irr.req. for actual area (l/s/ha)	0.15	0.29	0.41	0.35	0.08	0.02
	Gross Irr.req. for actual area (l/s/ha) for surface (60% eff.)	0.25	0.48	0.68	0.58	0.13	0.03
	Gross Irrig. Req.for 385 ha (l/s)	96.25	184.80	261.80	223.30	50.05	11.55

### **Operational scheme irrigation needs (SINop)**

From Table 3 the highest gross irrigation requirement for 385 ha was 261.8 l/s which need to flow for 24 hour in scheme but most of working time for irrigation scheme is 12 hour per day.

The calculated SINop for 12 hour was 523.6 l/s. So this was the design discharge of main canal for command area.

### Reservoir capacity determination

The reservoir capacity was determined depending on water required for the command area and continuous flow of spring water from the reservoir. During study time average continuous flow measurement was taken at different time from reservoir (spring water discharge measured after reservoir gate opened and constant water flow reached from reservoir) was 50 l/s but the canal must supply a discharge of 523.6 l/s for 12 hour. The current capacity of reservoir as 2604 m<sup>3</sup> was measured; however the command areas need 20, 476.8 m<sup>3</sup> additional water to supply the required amount. Therefore, 20,476.8 m<sup>3</sup> is the redesign capacity of reservoir.

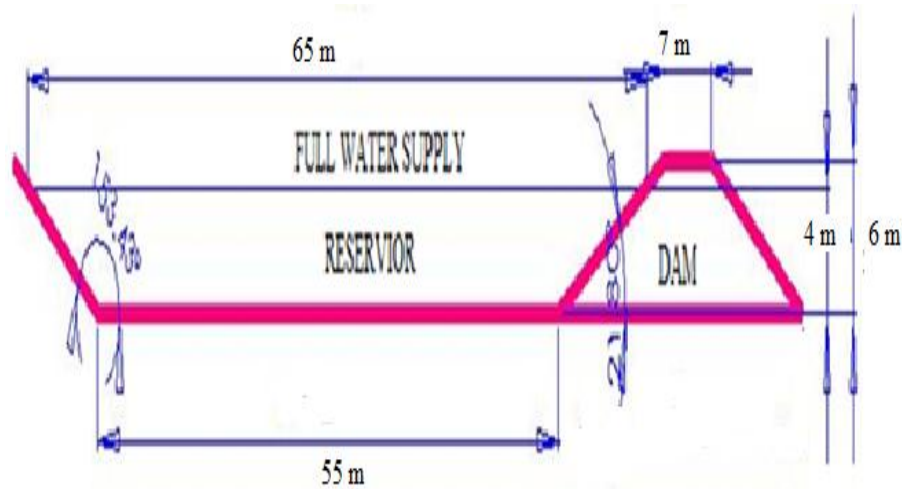

Figure 1. Redesigned reservoir dimension

### Distribution structure design

Since soil of the irrigation scheme was loam, safe side slopes are taken as 1.5:1, Manning's coefficient of 0.02 were assumed and design discharge of 524 l/s was calculated.

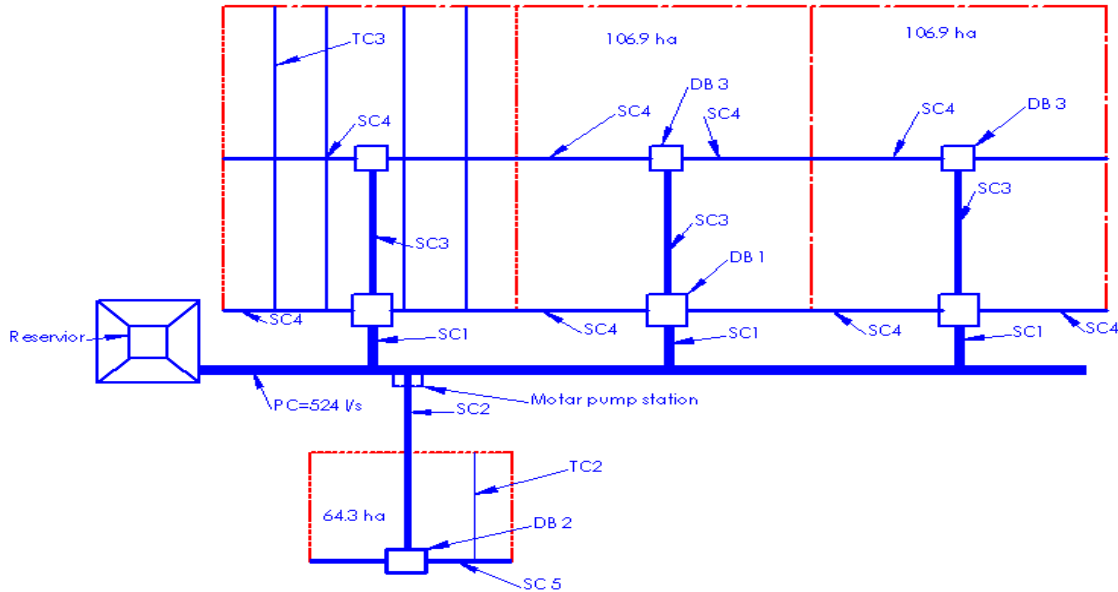

Figure 2. Distribution structure of scheme and command area

### Main canal

The main canal of scheme was started from reservoir and discharges 524 l/s to command area. The dimensions of the canal were 253.95cm, 74 cm for top and bottom width and depth of 60 cm Table 4.

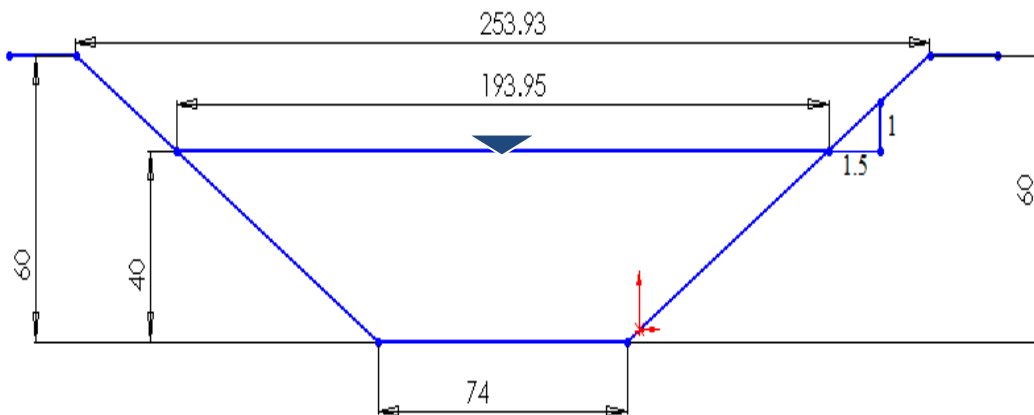

Figure 3. Redesigned main canal dimension in centimeter



## Secondary canal

Table 3 is showing summary of discharge and dimension of secondary and tertiary canals. From this table secondary canal 1 (SC1) off-take  $0.146 \text{ m}^3/\text{s}$  of discharge from main canal to division box and have 0.39 m of canal depth and 0.5 m bottom width. Secondary canal 2(SC2) off-take  $0.087 \text{ m}^3/\text{s}$  pumped by motor pump to division box 2 that distribute to secondary canal 5(SC5) (Figure 2) which have capacity of  $0.044 \text{ m}^3/\text{s}$  and canal depth of 0.26 m and bottom width of 0.28 m. The secondary canal 3, 4 and 5 also discharges 0.073, 0.036 and  $0.044 \text{ m}^3/\text{s}$  of water and have canal bottom width of 0.36, 0.26, 0.28 m and canal depth of 0.29, 0.25 and 0.26 m respectively.

## Tertiary canal

The tertiary canal (TC) also distributes  $0.018 \text{ m}^3/\text{s}$  of discharge from secondary canal 4 and 5 (SC4 and SC5) to farm and have 0.23 m canal width and 0.16 m canal depth.

Table 4. Canals dimensions

Canal type	Water depth in (m)	Width in (m)	D/B ratio	Free board in (m)	Total canal depth (m)	Discharge ( $\text{m}^3/\text{s}$ )
MC	0.40	0.74	0.54	0.20	0.60	0.524
SC1	0.24	0.50	0.48	0.15	0.39	0.146
SC2	-	-	-	-	-	0.087
SC3	0.19	0.36	0.53	0.10	0.29	0.073
SC4	0.15	0.26	0.58	0.10	0.25	0.036
SC5	0.16	0.28	0.57	0.10	0.26	0.044
TC1	0.11	0.23	0.48	0.05	0.16	0.018

MC= Main canal, SC= Secondary canal and TC= Tertiary canal

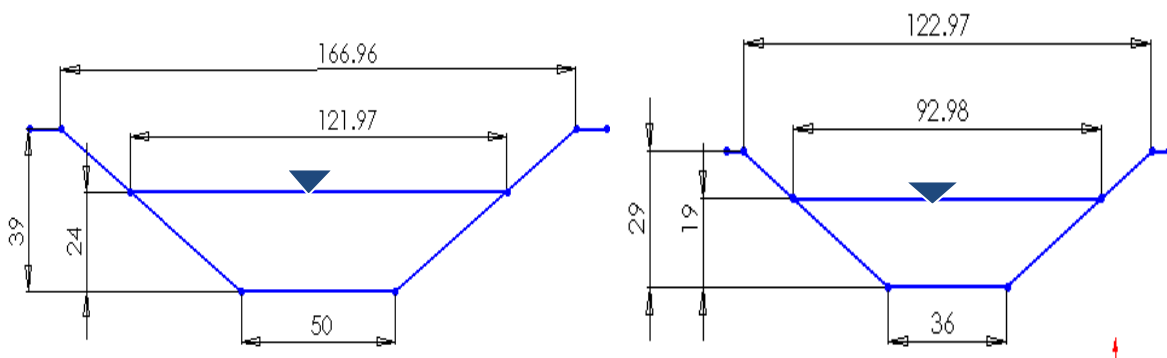

Figure 4. Secondary canal 1 and 3 (SC1 and 3) dimension in centimeter

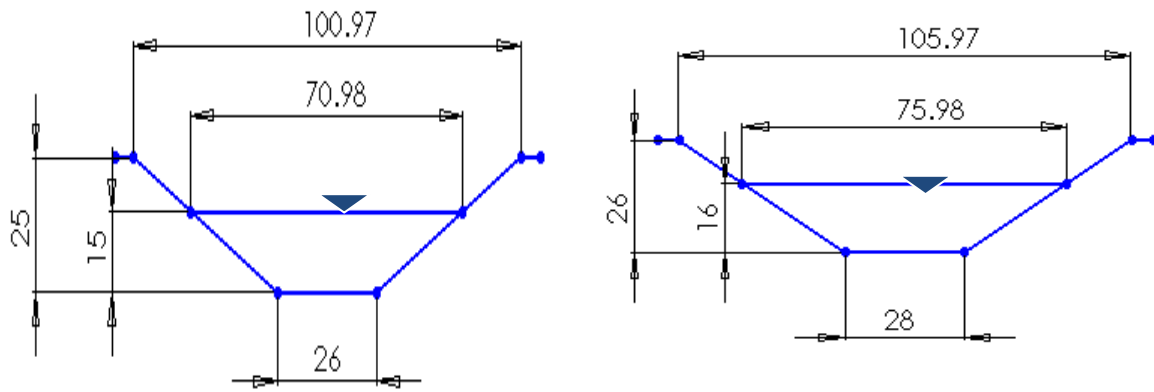

Figure 5. Secondary canal 4 and 5 (SC4 and SC5) dimension in centimeter

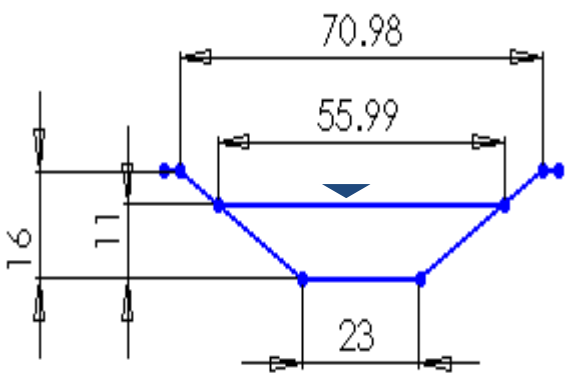

Figure 6. Tertiary canal (TC) dimension in centimeter

**Division box**

The discharge inlet to two way division box from secondary canal 1 (SC1) is  $0.146 \text{ m}^3/\text{s}$  was divided into three.

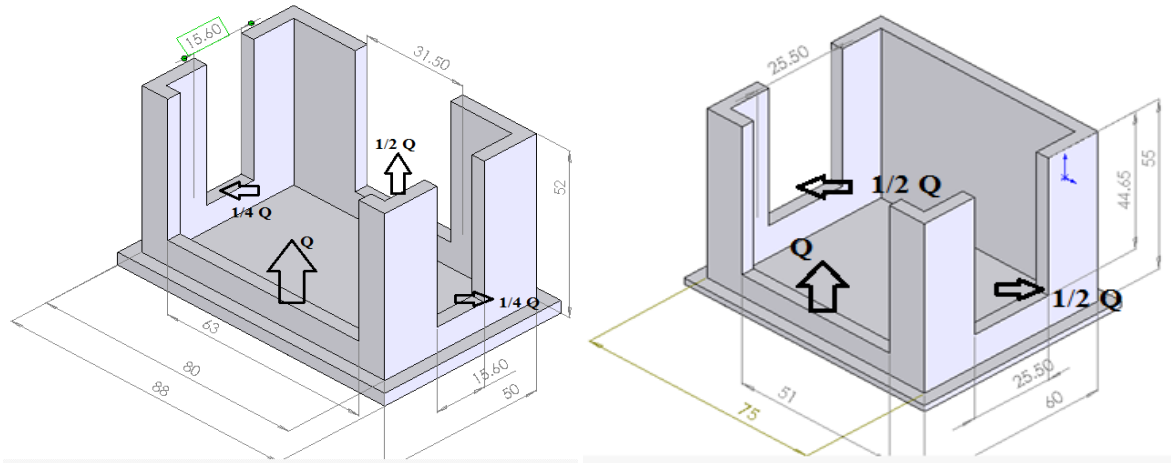

Figure 7. Three and two way division box 1 and 2

## CONCLUSION AND RECOMMENDATIONS

Irrigation is highly expected to play a major role in the realization of Ethiopian food security and poverty alleviation strategy. From this important viewpoint, irrigation projects are widely studied, planned and implemented throughout the country. However, little or no attention is given to the monitoring and evaluation of the performance of already established irrigation schemes.

The scheme has trapezoidal shape of reservoir with a capacity of 2604 m<sup>3</sup> live storage along with trapezoidal shape of main canal with average size of 161, 59, 38.2 cm at the top, bottom and depth respectively and maximum discharge capacity when gate was fully opened at off-take was 70 l/sec.

The aim of this study was to redesign Mada Batu scheme to balance with current actual command area irrigated and water supply capacity of the scheme. The current redesigned capacity of main canal was 524 l/s with its corresponding dimensions 253.9, 74 and 60 cm at the top, bottom and depth respectively.

It is recommended for district irrigation development authority to solve the conflict between the farmers by making this research as base line information, further studies should also be

carried out to determine required water supply to command area, to measure continuous water flow (spring water flow from reservoir) and detail land survey for detail scheme redesign.

Until the solution will come (redesign implemented) the district irrigation expert give training for farmers on water use and fix the schedule depending on crop water requirement. The canal maintenance and the reservoir cleaning are needed to increase the discharge and decrease the loss.

### **ACKNOWLEDGEMENTS**

The authors thank Oromia Agricultural Research Institute (IQQO), for providing the scholarship and financial support for the research, Haramaya University, Malkesa Resarch Center and Zuway Soil Laboratory Center for providing necessary field equipment and facilitating laboratory work and Gedab-Asasa Irrigation Development Authority for allowing me to get necessary documents and study site.

### **REFERENCES**

- Bayan Ahmed. 2017. Technical performance evaluation of mada batu small scale irrigation scheme , west arsi zone of oromia region. International journal of engineering research-online.” 5(3):269–76.
- CIA (Central Intelligence Agency). 2016. Ethiopia GDP and Economic Data <https://www.cia.gov/library/publications/the-world-factbook/fields/2012.html#84>
- FAO (Food and Agriculture Organization). 1989. Guidelines for Designing and Evaluating Surface Irrigation Systems. Irrigation and drainage paper No. 45. Rome, Italy.
- IWMI (International Water Management Institute). 2010. Irrigation potential in Ethiopia:- Constraints and opportunities for enhancing the system.
- Michael P. M. and John W. J. 1991. Calculating Area and Volume of Ponds and Tanks. SRAC. No. 89-38500-4516, USDA.
- MoWR (Ministry of Water Resources). 2002. Water Sector Development Programme 2002-2016, Volume II: Main Report. Ministry of Water Resources, Federal Democratic Republic of Ethiopia, Addis Ababa.
- NRMD (Natural Resources Management Directorate). 2011. The Federal Democratic Republic of Ethiopia Ministry of Agriculture Natural Resource Sector Small-Scale Irrigation Capacity Building Strategy for Ethiopia.

- Rani,R.Y., Venkateswarao, B. and Sreekanth, S. 2011. Modernization of an Existing Irrigation Project by Performance Evaluation Using Performance Indicators. International eJournal of Mathematics and Engineering 141: 1273–92.
- Robel Lambiso. 2005. Assessment of Design Practices and Performance of Small Scale Irrigation Structures in South Region. M.Sc. Thesis. Arba Minch University, Ethiopia
- Seleshi Bekele Awulachew, D.J. Merrey, A.B. Kamara, B. Van Koppen, F. Penning de Vries and E. Boelee. 2005. Experiences and Opportunities for Promoting Small-Scale/Micro Irrigation and Rainwater Harvesting for Food Security in Ethiopia. IWMI Working Paper 98. Colombo, Sri Lanka.
- Seleshi Bekele, Aster Denekew, Makonnen Loulseged, Loiskandl, W., Mekonnen Ayana, and Tena Alamirew. 2007. Water Resources and Irrigation Development in Ethiopia. Working Paper 123. Colombo, Sri Lanka.

# Redesigning of Ketar Medium Scale Irrigation Scheme, Arsi Zone of Oromia Regional State, Ethiopia

Dinka Fufa

Oromia Agricultural Research Institute, Asella Agricultural Engineering Research Center P.O  
Box 06, Asella Ethiopia  
[dinkfuf@yahoo.com](mailto:dinkfuf@yahoo.com)

---

## Abstract

*Redesign of irrigation scheme is required when the scheme is performing under its designed capacity and expansion is aimed. The scheme Redesign was done due to low conveyance efficiency and existence of runoff and deep percolation loss. Design of lined secondary canal with flow of  $0.518\text{m}^3/\text{s}$  was made. New reservoir of capacity  $26,891.2\text{m}^3$  was also designed due to silt accumulation for previous one. The study was concluded as upper and middle stream users were consuming more water than the lowers with decreased productivity of the scheme and thus technical support and SWC activities in this watershed are recommendable for sustained use of design discharge.*

**Keywords:** *Irrigation Scheme, Design parameters, Redesign, Efficiency improvement*

## INTRODUCTION

Design of a surface irrigation system may be required for either a planned new irrigation scheme or an existing irrigation scheme where low performance requires improvement by redesigning the system. In both cases, the data required fall into six categories: the water resources to be used, including source of water, flow rates and water quality, the topography of the land surface, the physical and chemical characteristics of the soil, including infiltration rates, soil moisture holding capacities, salinity, the expected cropping pattern, the economic and marketing situation in the area and the availability of services, including the availability of labour, maintenance and replacement services, energy, availability of capital for the work, farming practices of the overall farming enterprise (Andreas and Karen, 2002).

Good design incorporated with good management of irrigation systems is critical to achieving high irrigation efficiency. Without good design, irrigation efficiency improvements that can be made with management are limited and are in fact hampered (Bright *et al.*, 2000; cited by Rose, 2006). Lining of canals is an important feature of irrigation projects as it improves the

flow characteristics and minimizes the loss of water due to seepage (Kisan *et al.*, 2000). Technical performance evaluation conducted on Ketar scheme had shown conveyance efficiencies of 66.86, 56.50 and 48.90% at Ketar-1, Ketar-2 and Ketar-3 main canals, respectively. As stated by FAO (1989), for earthen canal length more than 2000 m constructed on clay soil its conveyance efficiency would be 80% whereas 95% for lined canal. Conveyance efficiency of the Ketar scheme was estimated as 57.40%. From that result it was concluded that conveyance efficiency of Ketar scheme was found poor (Dinka, 2017). Hence, this study was aimed to redesign of Ketar medium scale irrigation system to improve its efficient based on the performance evaluation. As stated by FAO, (1989), for earthen canal length >2000m constructed on clay soil its conveyance efficiency would be 80% where as 95% for lined canal.

## **MATERIALS AND METHODS**

### **Description of study area**

The study has been conducted on Ketar medium scale irrigation scheme situated in Tiyo woreda, Arsi Zone of Oromia Regional State. The woreda is bordered on the south by Munesa, on the west by Ziway Dugda, on the northeast by Hitosa, and on the southeast by Digeluna Tijo. A survey of the land in this woreda shows that 40% is arable or cultivable (32% was planted with cereals), 23.1% pasture, 8.7% forest, and the remaining 28.2% is considered swampy, mountainous or otherwise unusable (Yazachew and Kasahun, 2011).

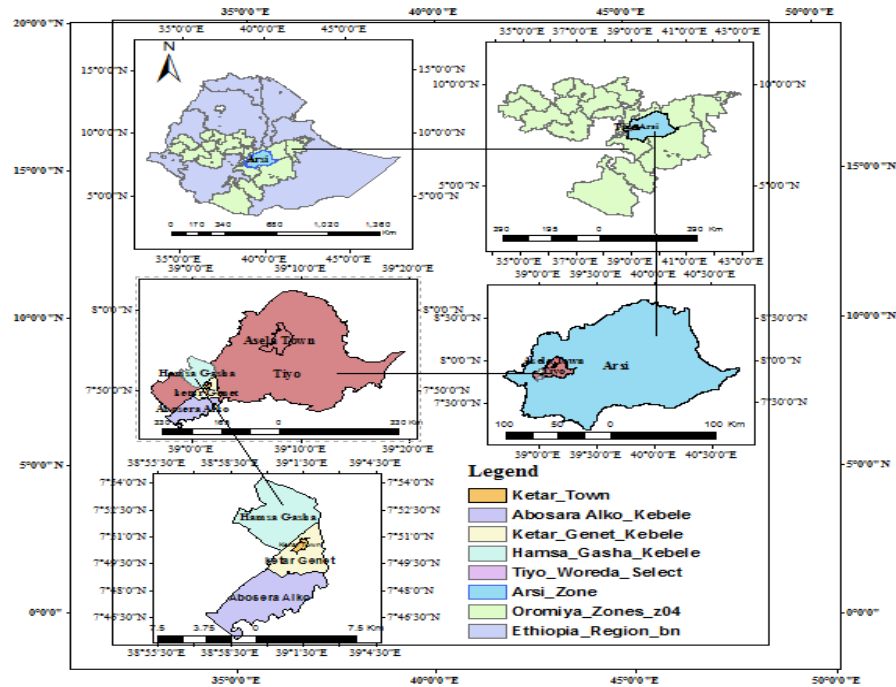

Figure 1. Location map of study area

## Data collection

### Primary data collection

To check the performance of the scheme discharge rate at main, secondary and tertiary canals were measured. Three inch (3") parshall flume was used to measure discharge through field channel. Based on respective shapes of canal a point measurement had been taken. For calculating area; for regular canal shapes canal like trapezoidal and rectangular their respective formulas were used and for irregular shapes or earthen canals it was done by dividing into small partitions of trapezoidal shapes across the canal and the total area was computed by summation of each partition. Discharges were measured at necessary points of diversion weir and primary, secondary, tertiary and field channel at head, middle and tail locations of the scheme.

### Secondary data collection

Secondary data was collected includes; original scheme parameter design command area and scheme management. Secondary data was collected from woreda irrigation office like procurement of necessary documents and other useful written and published materials related to the scheme.



### **Scheme characterization**

Scheme characterization included description of the structures starting from diversion head work through irrigation regulators up to command area based on the type of irrigation method being used at project area. To carry out this, visits and observations of the scheme was done and functionality of the structures was assessed. Thereafter it was compared with the design document which had been prepared for scheme.

### **Redesign and maintenance of the scheme**

Redesign was aimed as conveyance efficiency of the scheme was poor and has significant runoff loss. To carry out this observation of scheme structures was done to identify functionality of structures as per their design. Tail water runoff, seepage losses and deep percolation losses were observed in conveyance as well as field channel. During redesign of the scheme maximum water demand or ETo or ETc crop was selected from surrounding to compute system design capacity. This computed value was compared with the capacity of the canal and redesign was done at whether the scheme is under performing or over performing. Redesign of all damaged or out of function canals were observed starting from diversion to field channels based on design criteria for the improvement of the performance of the scheme. This activity was carried out either the scheme is under performing or excess water is being applied to the crop. For redesigning earthen canal by lined, Manning equation was used for calculating flow rate. If the flow rate is sufficiently close to the desired maximum discharge value, the design process will be finished. If the flow rate is not the desired value, change will be made to the side slope, m, and or bed width, b, checking the m and b/h limits which may have set initially. Design of lined canal was made based on amount of irrigation water loss from conveyance, tail water runoff and deep percolation, for increasing irrigable area of the scheme.

That design also depends on peak demand of the study area crop. For redesigning the scheme Manning equation and Chezy equation (applied successfully on steeper slope) were used.

$$Q = \frac{1}{n} AR^{\frac{2}{3}} S^{\frac{1}{2}} \text{ (Manning equation)} \quad (2.4)$$

$$Q = CA\sqrt{RS_o} \text{ (Chezy equation)} \quad (2.5)$$

Where:- Q=Discharge through the canals (m<sup>3</sup>/s)

A=Cross sectional flow area (m<sup>2</sup>)

N=Manning coefficient

S<sub>o</sub>=Longitudinal slope (%)

R=Hydraulic radius (the ratio of cross sectional area and wetted perimeter)

C =Chezy's coefficient (0.60-0.69)

Design Daily Irrigation Water Requirement (DDIR<sub>p</sub>)

$$DDIR = \frac{RAW}{T_{\min}} = \frac{AD}{T_{\min}} \quad (2.6)$$

Where: DDIR=Design Daily Irrigation Water Requirement

RAW=Readily Available water (mm)

T<sub>min</sub>=Minimum Interval (days)

AD=Allowable Depletion (mm)

Redesign was done for conveyance loss of the scheme. It was determined from conveyance loss from diversion up to reservoir. For determining conveyance loss of the scheme, it was observed from diversion to Ketar-1, Ketar-2 then Ketar-3. To determine conveyance loss at Ketar-2 loss determined at Ketar-1 was deducted and, for Ketar-3 loss at Ketar-2 was deducted. In case of Ketar-3, measurement was done when water level reached constant point. Over all loss=Ketar-1+ (Ketar-2-Ketar-1) + (Ketar-3-Ketar-2).

Design of Reservoir (night storage) for Ketar-3 or tail scheme was done due to siltation effect of the former one. An irrigation reservoir is defined as “an irrigation water storage structure made by constructing a dam, embankment, pit, or tank” (NRCS, 2011). Storage reservoirs can provide a consistent supply of irrigation water, provide storage for farms with tail water recovery, and reduce energy costs. These reservoirs are used in cases where pumps are insufficient to provide enough water for irrigation requirements, where water can be taken from streams, surface runoff, or groundwater. In order for a reservoir to be useful, the existing water supply must be insufficient to meet crop requirements, water is available for storage from some source and a site is available for the reservoir (NRCS, 2011). Design of the reservoir was made at land which is beside the former constructed one. The shape of newly designed reservoir is trapezoidal frustum. Silt excluder was also designed before water enters

the reservoir. Design capacity (size) of the reservoir (night storage) was based on the amount water which would be stored farmers could use next day.

## RESULTS AND DISCUSSION

### Scheme characterization

Ketar medium scale irrigation scheme is diverting from Ketar River which feeds Lake Ziway. It has flume which conducts the water to steep hill side as there is gully nearby diversion weir. The scheme was designed for 400 ha with design discharge of 860 l/s ( $0.86\text{m}^3/\text{s}$ ), which means designed water duty is 2.15 l/s/ha. But current observed discharge was  $0.80\text{m}^3/\text{s}$ . Farmers were using this water to irrigate land which is larger than designed command area. Crops which dominantly grown are potato, onion, cabbage (*Gomen*), Head Cabbage, Carrot and Pepper. Farmers were using traditional water application as they were not applying intended amount of water which would be applied based on crop type, soil type and crop growth stages. Most part of the scheme is earthen canal even the main canal, which leads to seepage and deep percolation loss of water before it reaches farmers' field. This project was constructed by government and rehabilitated by OIDA in cooperation with JICA. There was no enough data available on the design of the scheme. From observation done for the project there are broken canal through which conveyance loss occur and there was mismanagement of water particularly gates were not closed after use which cause discharge reduction for the next user and shortage of water that reach night storage during night.

Table 1. Quantity and length of structures of Ketar scheme

No	Particular	Number /quantity			Length (m)		
		Ketar-1	Keta-2	Ketar-3	Ketar-1	Keta-2	Ketar-3
1	Division box	5	10	1	-	-	-
2	Irrigation pond	1	1	12	-	-	-
3	Main canal	1	1	1	-	3170	-
4	Secondary canal	6	2	1	3653	5930	1670
5	Tertiary canal	-	7	1	-	1943	3690
6	Area boundary	7	10	12	8540	-	-
7	Farm boundary	1	1	1	653	-	-

Ketar-2 main canal discharge was 0.452 m<sup>3</sup>/s. Ketar-2 secondary discharge was 0.057m<sup>3</sup>/s. Main canal of Ketar-3 is rectangular canal 0.75 m width and 0.25 m water level height (H). Using discharge measurement by structure formula for rectangular notch (sharp crested rectangular opening is ( $Q = \frac{2}{3}c_d\sqrt{2g}LH^{3/2}$ ) where c<sub>d</sub> (coefficient of discharge) value is 0.60-0.69. Discharge at this point was 0.391m<sup>3</sup>/s. Discharge of Ketar-3 secondary canal was computed in Table below by mean velocity method.

### Conveyance efficiency of the scheme

Conveyance efficiency of the station 1, 2 and 3 are 66.9, 56.5 and 48.9% respectively. Average Scheme conveyance efficiency of Ketar scheme was 57.4%. As stated by FAO, (1989), for earthen canal length >2000m constructed on clay soil its conveyance efficiency would be 80% where as 95% for lined canal. From that result it is concluded that conveyance efficiency of Ketar scheme was poor.

Table 2- Efficiency parameters of Ketar Irrigation Scheme

Stations	Efficiency Parameters							
	Ec (%)	Es (%)	A <sub>Uni</sub> (%)	Ea (%)	(RR) (%)	(DPF) (%)	IWUE (kg/m <sup>3</sup> )	Df (%)
Ketar-1	66.90	202.20	59.98	57.19	34.75	8.06	2.13	72.80
Ketar-2	56.50	141.30	64.78	65.51	25.33	9.16	2.79	69.10
Ketar-3	48.90	136.50	60.03	62.10	23.51	14.39	2.23	68.5
Scheme	57.40	160.00	61.60	61.60	27.86	10.54	2.38	70.10

Ec=Conveyance Efficiency, Es= Storage Efficiency, A<sub>Uni</sub>=application uniformity, Ea=Application Efficiency, RR=Runoff Ratio, DPF= Deep Percolation Fraction, IWUE= Irrigation Water Use Efficiency, Df= Depletion Fraction

### Redesign and maintenance of the scheme

Redesign was made by changing earthen canal to lined starting from diversion head work which had discharge of 0.8 m<sup>3</sup>/s. Bed width of canal was 0.6m and average flow depth was 0.53 m. Designed canal was trapezoidal using which was calculated by using Manning formula. The existing canal side slope of obtained during data collection for characterization this scheme was 1.8:1. The measured value of wetted cross-section area (A) of the canal was

9.82 m<sup>2</sup>. Lining was designed to construct canal by concrete. Manning roughness coefficient (n) value for lined canal bed constructed from concrete is 0.017.

Redesign was based on conveyance loss, runoff and deep percolation losses which took place at each stations and redesign of night storage of lower/tail station as well. Estimated amount of total water loss from only runoff and deep percolation was 1,144,937.11 cubic meter per season. Average conveyance efficiency of the scheme was 57.4%, thus 42.6% water from diversion was conveyance loss. It was 42.4% of 0.8 m<sup>3</sup>/s, which equals 0.341m<sup>3</sup>/s. Maximum seasonal crop growth length is 150 days. Crops dominantly grown in Ketar scheme were Potato, Onion, and Cabbage on clay loam soil. From this seasonal conveyance loss was 4,419,360m<sup>3</sup>. Conveyance efficiency of lined canal is 95%. So 95 % of 0.518 m<sup>3</sup>/sec (0.492 m<sup>3</sup>/sec) can reach farm field. It is difficult to stop deep percolation loss rather runoff. Net irrigation depth for those four crops growing at the scheme was 45 mm and application efficiency of surface irrigation is 60% as stated by FAO water management manual. From that gross irrigation depth was 75 mm

Table 3. Summary of water loss in Ketar Irrigation scheme

Station	Average plot area (m <sup>2</sup> )	Average loss (m <sup>3</sup> )	Current command area (m <sup>2</sup> ) x10 <sup>4</sup>	Runoff and deep percolation loss (for 12 hours daily) (m <sup>3</sup> )	Conveyance loss (for 24 hours daily) (m <sup>3</sup> )	Discharge at each station (m <sup>3</sup> /s)	Redesigned command area(ha)
Ketar-1	1191.67	361.81	143	330939.24		0.282	188
Ketar-2	1233.33	192.13	248.5	312169.71		0.518	345
Ketar-3	1187.5	209.88	150	215093.86		0.391	262
Total	3612.5	763.82	541.5				795
Average	1204.17	254.61					
Scheme Losses (m <sup>3</sup> /season)				1,144,948.93	4,419.360		
Scheme loss (m <sup>3</sup> /sec)				0.177	0.341		
Total Scheme loss (m <sup>3</sup> /sec)				0.518			

Lining of canals was an important feature of irrigation projects as it improves the flow characteristics and minimizes the loss of water due to seepage. The water thus saved can be utilized for the extension and improvement of irrigation. According to Michael (2008), Irrigation interval at Climate-1 was chosen since for ET<sub>o</sub> of Ketar Scheme was 4.43mm/day

Canal design was made for discharge of  $0.518\text{m}^3/\text{s}$  for farm land located in Ketar-II and was out of WUA. Using Manning formula necessary parameters of the canal was computed as follow. According to FAO Irrigation Water Management, Manual 7, for lined canal constructed by concrete maximum permissible velocity and limiting side slope are 2 m/s and 1.5:1, respectively. Manning roughness coefficient value for concrete lining is 0.0170 as stated by Schwab *et al.* (1966). Based on peak periods of water requirement on clay loam soil, net irrigation depth (45 mm) and minimum irrigation interval of 6 days (Michael, 2008) were selected for designing. Application efficiency of surface irrigation was taken as 60%.

Table 4. Estimated irrigation schedule of common crops during peak periods in water requirement for clay loam soil (Michael, 2008)

	Loamy Soils				Clay Loam				Clayey Soil			
	Irrigation Interval (days)		Net Irrigation Depth (mm)		Irrigation Interval (days)		Net Irrigation Depth (mm)		Irrigation Interval (days)		Net Irrigation Depth (mm)	
Climate*	1	2	3		1	2	3		1	2	3	
1 Onion	4	3	2	20	6	4	3	25	7	5	4	30
2 Cabbage	8	6	4	40	9	7	5	45	10	7	5	50
3 Potato	4	3	2	20	6	4	3	25	7	5	4	30

1=Climate 1= $ET_o$  ranges 4-5mm/day, 2=Climate 2=  $ET_o$  ranges 6-7mm/day, 3= Climate  $ET_o$  ranges 8-9mm/day.

From crop water requirement and irrigation water requirement of crops which are dominantly grown in the scheme, canal expansion was designed. It has one secondary canal, two tertiary canals and one division box of as water reaches farm from main canal to farm which is located in Ketar-2, which was not there in designed previous command area.

The efficiency of furrow irrigation systems can often be improved by reducing the inflow rate after water has advanced to the end of the field by using a common practice is to cut back to 50% of the inflow. As lined canal has more advantages than earthen canal like insuring cross section stability from scour, low flow conditions, long economic life, and the earthen one is to be replaced by this one. For constructing lined canal on clayey soil, recommended side slope is 1.5:1 up to 2.5:1 (Kisan *et al.*, 2000). To prevent scouring of the side of canal, it is better to construct the bottom of canal curved.

Table 5. Computed design parameters for newly designed canal

Canal section	Q (m <sup>3</sup> /s)	V (m/s)	N	Z (m)	S <sub>0</sub>	A (m <sup>2</sup> )	R (m)	W <sub>p</sub> (m)	d (m)	B (m)	Area (ha)
SC	0.518	1.500	0.017	1.5	0.0055	0.345	0.202	1.713	0.37	0.38	345
TC1	0.217	1.500	0.017	1.500	0.0098	0.145	0.131	1.107	0.25	0.21	145
TC2	0.301	1.500	0.017	1.500	0.0080	0.201	0.152	1.318	0.26	0.38	200
95% efficient lined canal											327.75

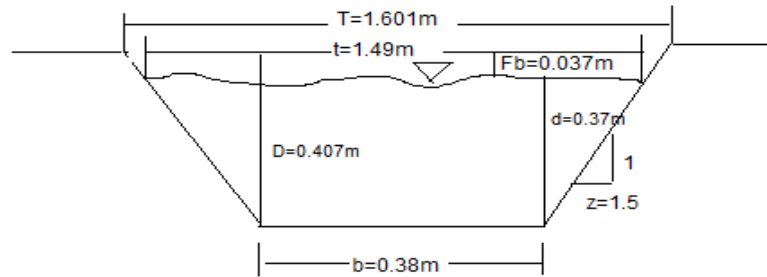

Figure 3. Cross sectional view of redesign of secondary canal

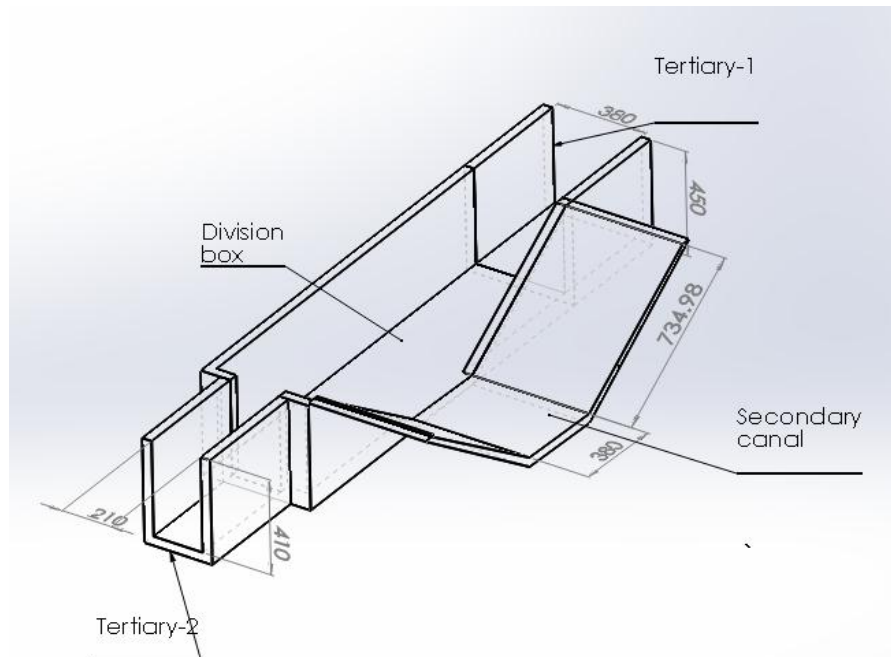

Figure 4- Isometric View of Redesigned Canal

Gross irrigation depth was 75 mm ( $100 \cdot d_{net} / E_a = 100 \cdot 45 / 60$ ). Minimum irrigation interval was 6 days. 75 mm every 6 days is 12.5 mm/day rounded to 13 mm/day which is equal to water duty of 1.50 l/sec/ha or  $1.5 \times 10^{-3} \text{ m}^3/\text{sec}/\text{ha}$  using conversion factor of 1 l/sec/ha=8.64mm/day.

Design discharge was  $0.518 \text{ m}^3/\text{sec}$ . For irrigating an area of 1 ha, the continuous flow was  $1.5 \times 10^{-3} \text{ m}^3/\text{sec}$ . From this  $0.518 \text{ m}^3/\text{s}$  can irrigate 345ha.

Redesign was also made for reservoir which was seriously affected by silt accumulation. Design of reservoir was made to store water which reach Ketar-3 main canal which was found as  $0.391 \text{ m}^3/\text{s}$ . Storage time is for 12 hour during night. Based on this reservoir which has capacity  $16,891.2 \text{ m}^3$  ( $0.391 \text{ m}^3/\text{s} \times 12 \times 3600 \text{ sec}$ ) was designed. Evaporation from shallow water bodies can also be approximated by multiplying reference  $ET_o$  by coefficient of 1.05 (*Allen et al.*, 1998). Thus, evaporation becomes  $4 \text{ mm/day} \times 1.01 = 4.04 \text{ mm/day}$  or  $4.04 \times 10^{-3} \text{ m}$  and multiplied by reservoir water surface area ( $4.04 \times 10^{-3} \text{ m/day} \times (76.61 \text{ m}^2)$ ) which is  $23.71 \text{ m}^3/\text{day}$  or  $0.0006 \text{ m}^3/\text{s}$ . When evaporation deducted from reservoir inflow ( $0.518 \text{ m}^3/\text{s}$ ), the value will be  $0.5174 \text{ m}^3/\text{s}$ . Farm which can be irrigated is also decreased to 344.93 ha.

A 3:1 side slope was chosen in order to ensure slope stability and to comply with NRCS Code 378 which states that outer slopes must be 3:1 or flatter and was used for reservoir design. To prevent seepage loss in the reservoir, covering its inner by geo membrane is recommendable. Shape of designed reservoir was truncate square prism or trapezoidal frustum whose top and bottom width are square. Designed reservoir has dimensions shown in Figure 5.

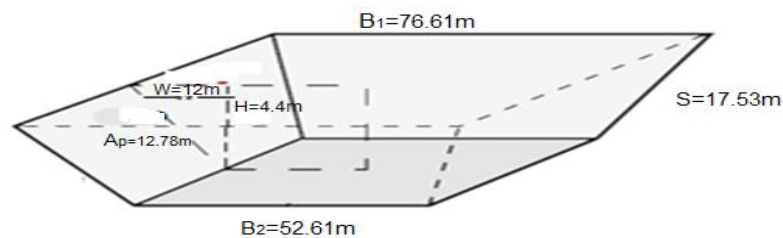

Figure 5. Isometric-View of designed reservoir truncate square prism

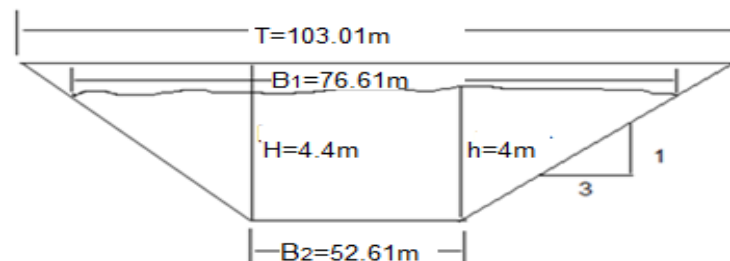

Figure 6. Cross section of designed truncate square prism reservoir



Generally, new redesigned command area can increase previously designed command area which was irrigating 431.50 hectare to 795 hectare. This can be achieved by applying right amount of water at right time based on each crop water requirement grown on the command area guided by experts, avoiding miss-management of water by WUA and managing losses by conveyance, runoff and deep percolation.

## **SUMMARY, CONCLUSIONS AND RECOMMENDATIONS**

### **Summary and conclusions**

Average station runoff ratio were found as 34.75, 25.33 and 23.51% for Ketar-1, 2 and 3 consecutively and was 27.86 for the scheme and average deep percolation fractions of consecutive stations were 8.06, 9.16, and 14.39%. Based on ANOVA and Duncan Multiple range test, there was significant difference among stations in irrigation water use efficiency at 5% and 10% significant level, while there was no significance difference for storage efficiency and application uniformity at both significance levels. Design of lined secondary canal with flow of  $0.518\text{m}^3/\text{s}$  was made. New reservoir of capacity  $26,891.2\text{ m}^3$  was also designed.

### **Recommendations**

To reduce siltation problem of Ketar-3 night storage reservoir and to increase discharge of the scheme it is recommendable to do watershed management of the scheme by practices like soil and water conservation activities in the watershed in addition to newly designed reservoir. It is also recommendable to construct silt excluder at a point before water enters the reservoir to protect silt accumulation. Further research work is required adequately to use irrigation water properly now and more in the future since water scarcity may be bottle neck for crop production due to changing climate.

### **Acknowledgment**

Above all let my thank goes to Almighty God for seeing me through this work. The road often seemed rough and dark, but He remained my Light and Strength. I indebted wish to express my sincere gratitude and appreciation to my advisor Prof. Shoeb Quraishi for his unlimited assistance and professional expertise. I would also like to take this opportunity to express my

gratitude for the financial support provided by Oromia Agricultural Research Institute (OARI) and Asella Agricultural Engineering Research Center (AAERC). It is my pleasure to acknowledge Dr. Tilahun Hordofa and his staff members of Melkasa Agricultural Research Center, Irrigation Research Case Team for their cooperation through borrowing me research materials like core sampler and double ring infiltrometer. Mr. Tilahun Firomsa, Abera and Gutema of Ziway Soil Research Center also deserve unforgettable admiration for soil laboratory works. My sincere gratitude also goes to Tiyo Wereda Irrigation Authority for their hospitality during site and farmer selection and providing me secondary documents concerning Ketar Medium scale irrigation scheme. At the last but not the least, my appreciation also goes to my wife Jorge Fufa and sister in law Kume Fufa for nursing my lovely daughter Telile Dinka. .

## REFERENCES

- Allen, R.,Pereira, L.S, Raes, D. And Smith, M. 1998.Crop Evapotranspiration (Guidelines For Computing Crop Water Requirements.Fao Irrigation And Drainage Paper ,No. 56.Fao, Rome, Italy.
- Andreas, P.S. And Karen, F. 1990. Irrigation Planning, Deleopment, Monitoring And Evaluation Of Irrigated Agriculture With Farmers Participation, Volume Ii Module .Fao,Rome, Italy.
- Andreas, P. S. And Karen, F. 2002. Planning, Development Monitoring and Evaluation of Irrigated Agriculture with Farmer Participation. Food and Agriculture Organization Of The United Nations (Fao)Sub-Regional Office For East and Southern Africa (Safr) .Frontline Electronic Publishing ,Harare, Zinbabwe.
- Bright, J; Carran, P. And Mc Indoe, I. 2000. Designing Effective And Efficient Irrigation Systems. Report No 2788/1, Prepared For Maf Policy. Lincoln Environmental, A Division Of Lincoln Ventures Ltd., New Zealand.
- Buchanan,Tj.Andsomers, Wp. 1969. Discharge Measurements At Gaging Stations: `U.S.Geological Survey Techniques Of Water-Resources Investigations, Book3,Chap. A8, P 65, United States Government Printing Office, Washington Dc, Usa.
- Burt, C. M., Clemmens, A. J., Solomon, K. H.,Strelkoff, T. S, Bliesner, R. D., Hardy, L. A., Howell, T. A., And Eisenhauer, D. E. 1978. Irrigation Performance Measures: Efficiency And Uniformity. Asce Journal Of Irrigation And Drainage Engineering.San Luis Obispo, Ca 93407-0730.California Polytechnic State University, California, Usa.
- Dinka Fufa. 2017. Technical Performance Evaluation Of Ketar Medium Scale Irrigation Scheme, Southeast Of Oromia Regional State, Ethiopia, Vol. 9, No. 9,P13-21, Civil And Environmental Research, Issn 2224-5790 (Paper) Issn 2225-0514 (Online)

- Edkin, R. 2006. Irrigation Efficiency Gaps-Review And Stock Take, Report No L05264/2, Sustainable Farm Fund And Irrigation New Zealand, Aqualinc Research Ltd, New Zealand.
- Kisan, M., Sangathan, S., Nehru, J., Andpitroda, S. G. (2000). Criteria For Design Of Lined Canals And Guidance For Selection Of Type Of Lining [Wrd 13: Canals. Manakbhavan, 9 Bahadur Shah Zafar Marg, New Delhi, India.
- Michael, A. M. 2008. Irrigation Theory And Practice. 2<sup>nd</sup> Edition, Vika Publishing House Pvt.Ltd, New Delhi, India.
- Nrcs (Natural Resource Conservation Service). 2011. Usda. Assessment Of The Effects Of Conservation Project: *Ceap* Special Issue Of The Journal Of Soil And Water Conservation Presenting Findings Of The Nifa Ceap Watershedstudiesnrcs.Usda.Usa.
- Rose, E. 2006. Irrigation Efficiency Gaps - Review And Stock Take Sustainable Farming Fund And Irrigation New Zealand Report No L05264/2.Kinnect Group Publisher,New Zealand.
- USDA Natural Resources Conservation Service. 1998. Soil Quality Indicators. Prepared By The National Soil Survey Center In Cooperation With The Soil Quality Institute, Nrcs, Usda, And The National Soil Tilth Laboratory, Washington, Dc, Usa.
- Yazachew Etefa And Kasahun Dibaba. 2011.Physical And Socio Economic Profile Of Arsi Zone And Districts, Bureau Of Finance And Economic Development Regional Data And Information Process, Addis Ababa, Ethiopia.